



ROBOT MOVEMENT CONTROLLED BY NECKBAND SENSORS

Ms.M.Sruthi¹, Mr.K.Ranjith Reddy²

¹Assistant Professor, Department of ECE ,Malla Reddy Engineering College For Women,(Autonomous Institution), Maisammaguda,Dhulapally,Secunderabad,Telangana-500100

²Assistant Professor, Department of ECE ,Malla Reddy Engineering College For Women,(Autonomous Institution), Maisammaguda,Dhulapally,Secunderabad,Telangana-500100

Abstract

In the modern world that has become so fast-moving and self-centered, one needs to have a reinvigoration of sorts, to renew oneself. However, in quadriplegics, this aspect is restricted due to the fact that their limbs have become immovable. Nonetheless, many of the people with disabilities have their heads moving, an ability which can be employed to produce adaptive devices. Since these people are paralyzed below the head, they need some special wheels instead of being dependent on conventional methods that may be controlled by an analog joystick. This project emphasizes the development of location-controlled smart wheelchairs with the aim of enhancing daily independence for quadriplegic users. For this purpose, the accelerometer component is integrated with Arduino Nano in the proposed design.

Keywords: Quadriplegics, paralyzed, syndrome, Wheelchair, accelerometer, and Arduino Nano.

I.INTRODUCTION

For the family with individuals to move around within their dwelling or environment. They may find a wheelchair with intelligence to be a helpful aid. Maybe a wheelchair may have been created by combining recent advancements in the fields of robotics, automation, embedded systems, artificial intelligence, etc. Wireless control is possible by using the right connectivity method. Both head gestures and hand gestures can be used to operate the chair, along with any necessary instructions. Utilizing a PC while in a wheelchair was a prior advancement for this type of wheelchair. The latest wheelchairs are gesture/voice controlled thanks to this advancement.

However, such a type of technology is constrained by the fact that the wheelchair is becoming too large and can only be driven by sitting in it. This explains why consumers who use such wheelchairs do not provide positive comments. The suggested design reduces the cost of production while also making it simpler and easier to build a wheelchair.

Throughout many years, the growth and advancement of innovation have made an impact on certain elements of the way we live and continue in doing so in the future using increased capacity and unanticipated development. In our project, we did what we could to draw a connection between the development of modern technology and the need to maintain human comfort. The primary goal of this research is to steer a wheelchair using human control. This project is primarily

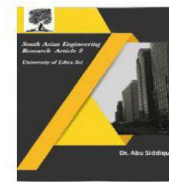

intended for people with physical disabilities who rely on wheelchairs, those who cannot use their hands to drag their wheelchairs due to an impairment.

Under this technology, the wheelchair's position is controlled by a head motion component that detects the user's movements. The Arduino platform was selected to construct the wheelchair concept because of its affordable price tag, adaptability, and effectiveness in performing mathematical tasks and connectivity to different electrical devices. The technique is cleverly designed and implemented to guarantee that when our enterprise is advertised, underprivileged clients in emerging nations may benefit from it. We believe that our initiative will result in some worthwhile operations, advance creativity, and most importantly help the person who produced the debilitation.

Sadly, the variety of disabled persons is growing daily because of both motor vehicle crashes and the illness that causes disability. Physically disabled persons make up the largest share of those with impairments. A person who is incapacitated depends on other people for daily tasks including transportation, food, and other things. Thus, a head motion-controlled wheelchair is created that moves automatically in response to the consumer's head motions for mobility. Those suffering from physical disabilities who are unable to independently walk or use an automated wheelchair benefit greatly from the accessibility of electrical wheelchairs.

II.THEORY

This section discusses the architecture of the wheelchair equipment and the elements that are required. The transmitter and receiver are both the components that make up the vehicle system. Figures 1 and 2 illustrate the block diagrams of the transmitter and receiver, correspondingly. Hardware and software components are the 2 categories into which elements fall.

This vehicle is constructed via an ATmega328 microprocessor and an RF module utilizing hand gestures. For the protection of those who are paralyzed, the current method tracks the wheelchair with a laptop. With the aid of an Arduino board, the computer is used to see the vehicle's position. The wheelchair essentially interprets the user's hand motions and standards, which are then shown on a laptop monitor. The motions of the hand in the current piece depict a little flexing of the hand done in various directions.

The ATmega328 microcontroller will provide the necessary signal via the encoder, HT12E, so that the concurrent information may be translated to serialized data and transmitted over the RF module after the decoding of a hand motion has been translated into machine code. The data is received at the receiver and transformed into sequential data by HT12D before being sent to the Arduino UNO board.

The DC motor driver is then signaled by the Arduino UNO board to shift and steer the vehicle in

the desired direction. Hand movements are detected and translated into movement of the vehicle in several directions, including left, right, forward, and backward, as well as stopping when necessary. A halt() function is activated by the microcontroller whenever the palm is equal to the ground's surface.

Arduino

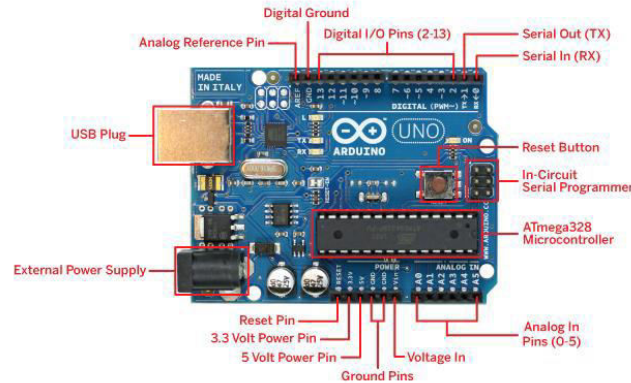

Figure. 1. Arduino Digital Fabrication

Different types of microprocessors and controllers are used in Arduino board designs. A variety of upgrades and other electronics can interact with the board's sets of digital and analog input/output (I/O) pins. The boards provide communication via serial ports that may be used to load software from a PC, particularly on certain models, Universal Serial Bus (USB). Typically, a dialect of elements from the C and C++ programming languages is used to code microcontrollers. The Arduino project offers an Integrated Development System (IDE) based on the Processing language project in addition to utilizing conventional compiler toolchains.

Arduino IDE

Arduino is an open-source prototyping platform built on simple hardware and software. It is comprised of a programmable circuit board and ready-built software called Arduino IDE (Integrated Development Environment), which is employed for generating and uploading computer code to the actual board.

Power Supply

The controlled power source provides the circuit with its input. The transformer steps down the ac input, or 230V from the mains supply, to 12V before feeding it to a rectifier. A pulsing DC voltage is produced by the rectifier as its result. Therefore, the output voltage produced by the rectifier is passed through an analog filter to eliminate any AC constituents that remain after conversion to obtain a pure DC value. To create a stable DC voltage, this voltage is now sent into a voltage regulator.

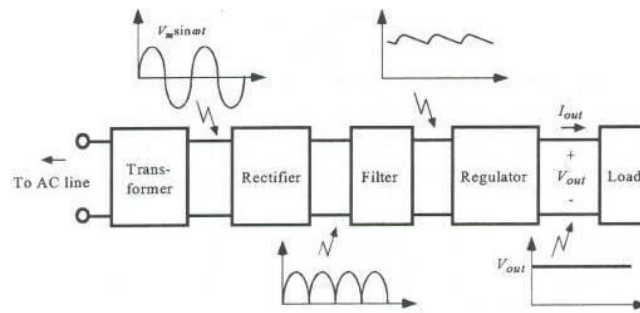

Figure. 2. Components of power supply

III.EXISTING SYSTEM

Older people and those with disabilities use vehicles primarily a form of transit. There is a couple of distinct kinds of smart vehicles on the market. It may be exceedingly difficult or impossible for someone with the illness to use a standard type of framework in specific circumstances, especially when they have ALS or Parkinson's disease and have a total lack of movement. It is influenced by nearby motion, eye location, voice recognition, brain waves, and other factors.

A self-propelled manual automobile typically has 4 wheels, two large wheels at the back and two large wheels for casters at the front along with a body, seat, and possibly a few foot plates. They created the software as well as the hardware for the monitoring system. The key drawbacks of this system are expensive, not flexible, and non-utility in public places.

IV.PROPOSED SYSTEM

The automobile moves by moving its head around, using displacement as a command to travel in an appropriate direction. These motions are monitored by a switch sensor. This sensor is attached to the head's cap. The microcontroller receives all these signals are inputs after trapping the fluctuations of the. The microcontroller is now designed to make judgments dependent upon such variances, which regulate the vehicle's movement. A chair can move to the right/left if somebody tilts their head to the right/left from underneath.

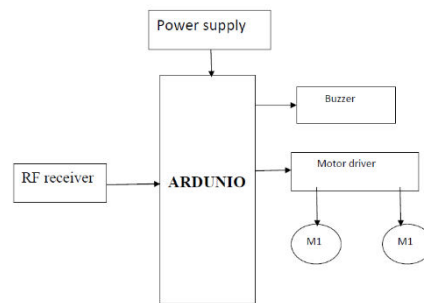

Figure. 3. Block diagram of the Motion controlled vehicle

The benefits of this system are quick design time, less production cost, Within a 50 cm span, the wheelchair identifies the obstruction in both directions and stops moving, paralyzed guy can control the armchair with absolutely any help from anybody else, The mechanism of the design is satisfactorily designed for moving the wheelchair in any of the directions Left, Right, Forward, and Backward or to keep it in place and consumes less power.

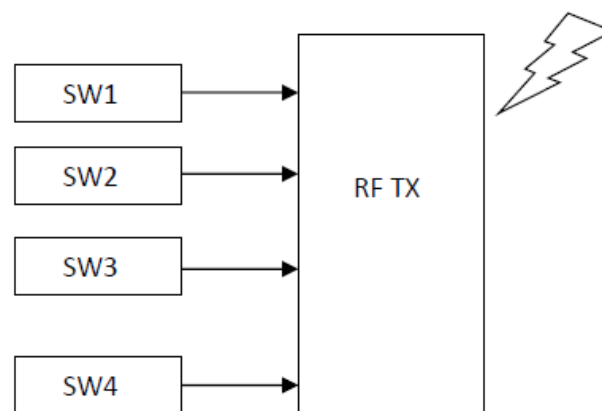

Figure. 4. Block diagram of Transmitter section

The central portion of the block representation represents the transmitter system, while another section represents the system that receives data. The transmitting device block diagram shown below illustrates how the transmitter circuit operates. First, details regarding various head movements are obtained using accelerometer data. The microcontroller receives all this data and makes the predetermined judgment. The RF transmitter finally sends the necessary command as the information.

The motor vehicle's operating scheme is depicted in the above diagram. The RF receiver receives the data from the transmitter component and sends it to the microcontroller. The microcontroller proceeds to make the choice since it is already programmed to control the automobile's motor and direction. To make the changing direction technique clearer, Motors 1 and 2 have been included.

V.RESULTS

The above-described components have all undergone independent laboratory testing to ensure appropriate operation. The intended wheelchair design can be built once all the parts have been attached. The operator's head is covered by a cap with the transmitters attached to it. The vehicle drives ahead when its operator lowers his head as seen in the first illustration.

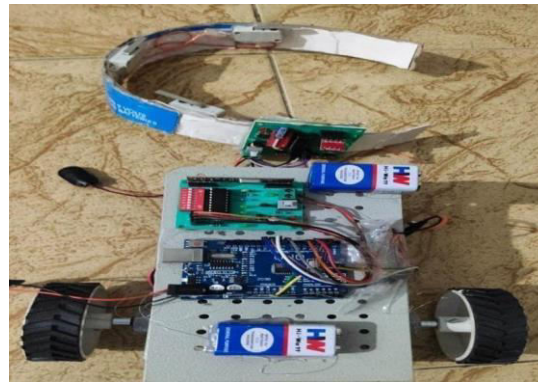
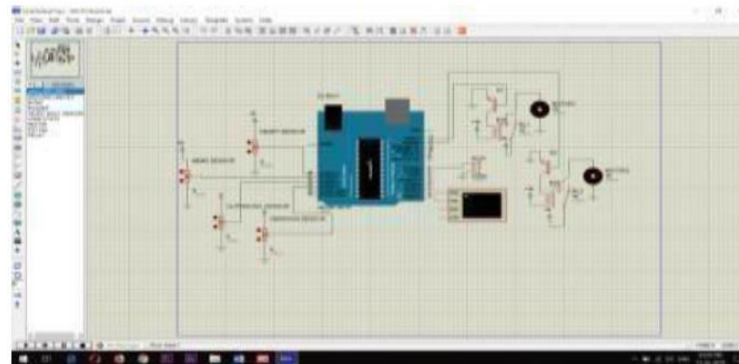

Figure. 5. Neck band-controlled robot

The automobile goes rearward by raising its head upward (represented in the second picture). The wheelchair stops after turning its head down while remaining stationary for 3 seconds at a time. The vehicle rotates to the right when the operator's head is tilted to the right. The vehicle also rotates to the left when the head is inclined in the left direction. Retaining the head in place for a



predetermined amount of time—in the case of the locked system, three seconds—is what creates the device that locks. The entire process is summarized in the table below.

Figure. 6. Stimulation output

The wheelchairs were developed for disabled patients who dropped a leg or had legs that were paralyzed. The objective of this project is to utilize a wheelchair absent a partner. This can be changed substantially in future generations.

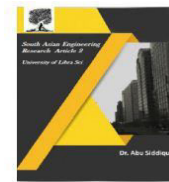

VI. CONCLUSION

The suggested body gesture-based digital wheelchair has been examined in a research facility and its findings are encouraging. The gadget is far less expensive than an equivalent import wheelchair since it is made entirely of locally available elements and electrical elements such as sensors, trans-receiver, microcontrollers, etc. Its operation is very easy and pleasant because of the wireless connection that exists between the transmitter ends, mounted on the back of the head (cap), and the reception device. The wheelchair that is being proposed for business manufacture may be an excellent substitute for one that is brought in and would be of tremendous assistance to the crippled individuals throughout our nation.

Using a MEMS component, this study clarifies the design and fabrication of a smart electronic wheelchair. Depending on the consumer's control, the electronic device may move around appropriately. While creating an interface that enables people with physical impairments to control their wheels using a MEMS sensor programme on their smartphone, it underwent testing and was found to be reliable. The microcontroller successfully manages the impediments monitoring process. The unwearable gadget detects any impediment that is predicted to reside within an extent of 4 meters as soon as the individual turns on the circuit's power and begins traveling. The concept behind the system helps mature individuals and others with various abilities become more independent.

VII. FUTURE SCOPE

Alternative to employing accelerator detectors, wheelchairs can move appropriately by detecting the visual cortex of the eyes via visual sensors. To reduce dangers when on the road, many dimensions and factors must be stimulated. Microcontrollers and speech-controlled ICs may communicate using one another. To expand the functionality of the current job, which includes message transmission during communications, the Global System for Mobility (GSM) might need to be included. The construction of wheelchairs for the disabled utilizing the nervous system of human beings is the subject of exploration.

We have the technology to create a remote-controlled wheelchair. Instrument signal is frequently utilized in wireless transmitters circuits and may be intercepted by reception electronic gadgets at recliner circuits. Therefore, wireless operations can minimize wire configurations. They can steer the wheelchair in a new direction without utilizing MEMS by employing an optical sensor that's attached to the retina of the eye. We would be equipped to operate a chair via tissue layer mobility. Investigators are working to enhance disability wheelchairs utilizing the nervous system of human beings. Sun-powered boards may be used to expand the construction of the wheelchair, which is more and more effective. The wheelchair is stimulated by the sun-powered panel itself. The only drawback is that a panel's layout and chair heaviness will both rise.

VIII. REFERENCES

[1]Rajesh Kannan Megalingam, Sai Monoj Prakhya, Ramesh Nammily Nair and Mithun Mohan, "Unconventional Indoor Navigation: Gesture Based Vehicle Control", 2011 International



Conference on Indoor Positioning and Indoor Navigation(IPIN).

[2]Sudheer kanuri, T V Janardhana Rao, Ch Sridevi and M S Madhan Mohan,” Voice and Gesture Based Electric-Powered Vehicle Using ARM”, IJRCCT, Vol 1, Issue 6, November 2012.

[3]V Sundara Siva Kumar, G.Ramesh and P Nagesh, “SWITCHES based Hand Gesture Wheel Chair Movement Control for Disable Persons”, International Journal of Current Engineering and Technology, Vol.5, No.3 (June 2015).

[4]Srishti, Prateeksha Jain, Shalu, Swati Singh, “Design and Development of Smart Vehicle using Voice Recognition and Head Gesture Control System”, International Journal of Advanced Research in Electrical, Electronics and Instrumentation Engineering (An ISO 3297: 2007 Certified Organization) Vol. 4, Issue 5, May 2015.

[5]Bickmore, T. and Cassell, J., 2004. J. van Kuppevelt, L. Dybkjaer, and N. Bernsen (eds.), Natural, Intelligent and Effective Interaction with Multimodal Dialogue Systems, chapter Social Dialogue with Embodied Conversational Agents.

[6]C. Sidner, C. Lee, C.D. Kidd, N. Lesh, C. Rich, Explorations in engagement for humans and robots, Artificial Intelligence 166 (1–2) (August 2005).

[7]Y. Nakano, G. Reinstein, T. Stocky, J. Cassell, Towards a model of face-to-face grounding, in: Proceedings of the Annual Meeting of the Association for Computational Linguistics, Sapporo, Japan, July 2003.

[8]Y. Matsusaka, T. Tojo, T. Kobayashi, Conversation robot participating in group conversation, IEICE Transaction of Information and System E86-D (1) (January 2003).

[9]R. Kjeldsen, Head gestures for computer control, in: Proc. Second International Workshop on Recognition, Analysis and Tracking of Faces and Gestures in Realtime Systems, 2001.

[10] K. Toyama, Look, Ma—No Hands! Hands-free cursor control with real-time 3D face tracking, in: Proceedings from the Workshop on Perspective User Interfaces, ACM Press, 1998, pp. 49–54.

[11] Wikipedia, Wikipedia encyclopedia[online]. Available FTP: en.wikipedia.org Directory: wiki/Dialog box, 2002.

[12] S. Lenman, L. Bretzer, B. Thuresson, Computer vision based hand gesture interfaces for human computer interaction, Technical Report CID-172, Centre for User Oriented IT Design, Stockholm, June 2002.