



## IMPROVED DESIGN OF WATCHDOG TIMER FOR SAFETY-CRITICAL APPLICATIONS

<sup>1</sup> KANDAVALLI SWETHA, <sup>2</sup>R.Vinay Kumar

<sup>1</sup>M.TECH VLSI, DEPT OF E.C.E, INTERNATIONAL SCHOOL OF TECHNOLOGY  
AND SCIENCE FOR WOMEN ANDHRAPRADESH,INDIA,533294

<sup>2</sup>ASSOCIATE PROFESSOR,INTERNATIONAL SCHOOL OF TECHNOLOGY AND  
SCIENCE FOR WOMEN ,ANDHRAPRADESH,INDIA,533294

### **ABSTRACT:**

Just recently, the regular coal mine security mishaps have actually triggered major casualties and also significant financial losses. It is immediate for the international mining market to raise functional effectiveness and also boost general mining safety and security. This paper recommends a light-weight mash up middleware to attain remote surveillance and also control automation of below ground physical sensing unit tools. Initially, the collection tree based upon Wireless Sensor Network (WSN) is released in a below ground coal mine, as well as suggests an Open Service Gateway campaign (OSGi)-based consistent tools accessibility structure. After that, recommend a consistent message area and also information circulation design, as well as, a light-weight solutions mash up method is carried out. With the aid of visualization innovation, the icon of various below ground physical sensing unit tools might be produced, which permits the sensing units to incorporate with various other sources quickly. Besides, 4 kinds of coal mine safety and security surveillance and also control automation situations are detailed, and also the efficiency has actually likewise been gauged as well as assessed. It has actually been verified that our light-weight mash up middleware could lower the prices effectively to develop coal mine security tracking as well as control automation applications.



## **INTRODUCTION**

BELOW GROUND mines are normally considerable mazes, which the passages are usually lengthy as well as slim with a couple of kilometers in size and also a couple of meters in size. Thou-sands of mining workers are should function under severe problems innng accordance with the building and construction needs, as well as numerous miners pass away from mining crashes yearly [1]-- [3] It is currently extensively accepted that the below ground mining procedures are of high threat. In sight of this, a surveillance as well as control system should be released as one crucial framework in order to guarantee the mining security as well as coordinate different jobs. Nevertheless, below ground coal mines primarily contain arbitrary flows and also branch passages, as well as this chaotic framework makes it really tough to release any kind of networking skeletal system. In such an instance, the usage of a cordless sensing unit network (WSN) as well as various other picking up tools could have unique benefits for recognizing the automation of below ground tracking as well as control because of the fast as well as adaptable implementation. Furthermore, the multihop transferring approach could well adjust to the passage framework as well as therefore supply adequate scalability for the building and construction of a mining system, as well as it is really ideal to the extensive tracking as well as control in coal mines, which could efficiently make up the shortages of the leaving below ground cord tracking system

## **EXISTING SYSTEM:**

An extensive number of mining staff are relied upon to work under incredible conditions as shown by the advancement essentials, and a few excavators fail horrendously from mining setbacks reliably . It is directly for the most part supported that the underground mining exercises are of high risk. In context of this, a watching and control structure ought to be sent as one crucial establishment remembering the ultimate objective to ensure the mining security and encourage distinctive assignments. In any case, underground coal digs generally include discretionary areas and branch sections, and this muddled structure makes it particularly difficult to pass on any frameworks organization skeleton



## **PROPOSED SYSTEM:**

This paper proposes a lightweight mashup middleware to achieve remote watching and control robotization of underground physical sensor devices. In any case, the bundle tree in light of ZigBee Wireless Sensor Network (WSN) is passed on in an underground coal mine, and proposes an Open Service Gateway action (OSGi)- based uniform devices get to framework. By then, propose a uniform message space and data scattering show, and moreover, a lightweight organizations smash up approach is executed. With the help of discernment advancement, the graphical UI of different underground physical sensor contraptions could be made, which empowers the sensors to unite with various resources easily.

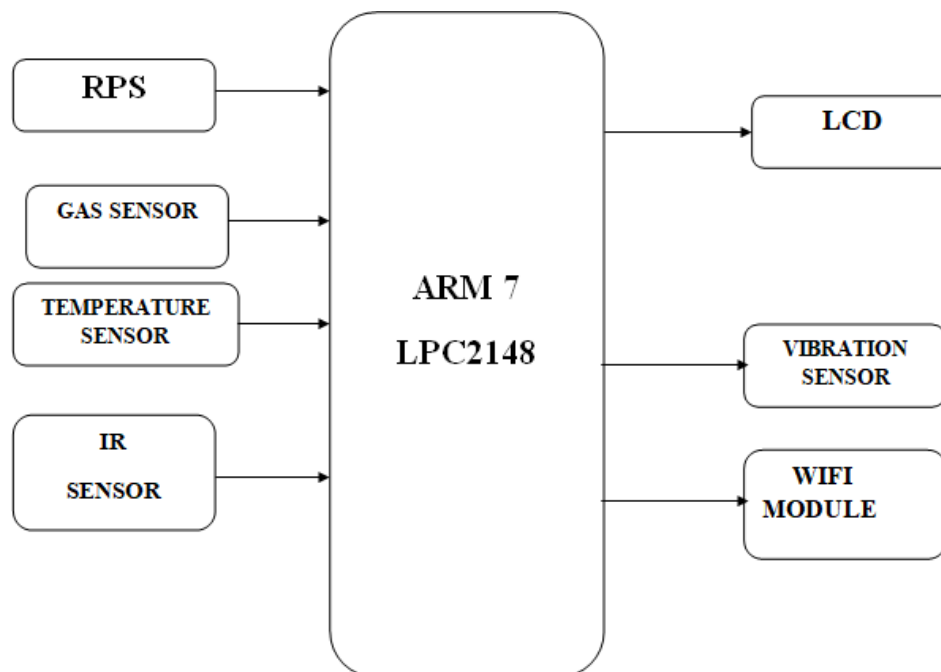

**4 Fig.6.1. Block diagram**

A considerable variety of extracting teamis trusted to function under unbelievable problems as revealed by the improvement fundamentals, and also a couple of excavators fall short

horrendously from extracting troubles dependably. It is straight, generally, sustained that thebelow ground miningworkouts are of high danger. In the context of this, a seeing and also control framework should be sent out as one essential facility keeping in mind the supreme purpose to make sure the mining safety and security and also motivate unique projects. All the same, belowgroundcoal digstypicallyconsist of optional locations as well as branch areas, as well as this jumbled framework makesit especiallychallenging to hand down any kind of structures company skeletalssystem..

## **RESULTS AND DISCUSSIONS:**

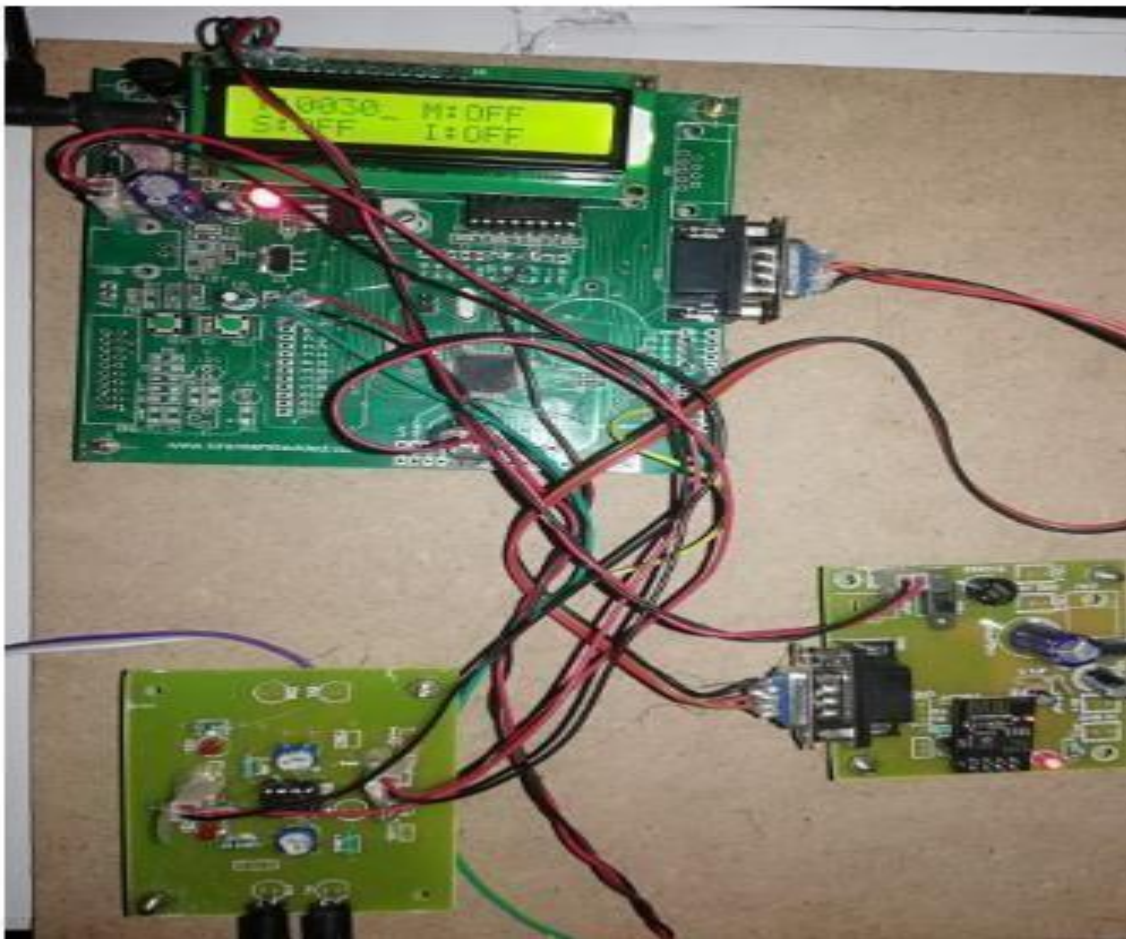

Fig.3.1.Hardwarekit.



Fig.3.2.Outputresults.

#### 4. CONCLUSION

The likelihood of "IOT" breaks standard reasoning and shows new thought, headway and system for flourishing supervision and association, takes a gander at to the sensible and security change thought, and reflects basic significance of rules of "Success and desire first, expansive treatment". Through getting a handle on IOT improvement for remote exceptional supervision, coal mine administering model can be pushed, following examination on unlawful development can be capable, limits of crisis reaction and incident examination can be expanded, state of safe age can be besides updated, and ensured and stable difference in coal industry can be advanced.



## REFERENCES

[1] K. Page, "Blood on the coal: The effect of business measurement and additionally qualification on coal mine accidents," *J. Wellbeing Res.*, vol. 40, no. 2, pp. 85--

95, 2009.

[2] L. Hammer, C. Vaught, and additionally M. J. Brnich Jr., "Sociotechnical communication in a subterranean mine fire: An exploration investigation of alarming messages all through a crisis circumstance release," *Safety Sci.*, vol. 16, no. 5, pp. 709--728,

1993.

[3] M. Nдох and also G. Y. Delisle, "Underground mines cordless reproducing demonstrating," in *Proc. 60th IEEE Veh. Technol. Conf.*, 2004, vol. 5, pp. 3584--

3588.

[4] J. Wood, J. Dykes, A. Slingsby, and furthermore K. Clarke, "Intuitive tasteful endeavor of a major spatio-fleeting dataset: Reflections on a revisualization mashup," *IEEE Trans. Vis. Comput. Chart.*, vol. 13, no. 6, pp. 1176 - 1183, Nov.- - Dec. 2007.

[5] X.-G. Niu, X.-H. Huang, Z. Zhao, Y.-

H. Zhang, C.-C. Huang, and furthermore

L. Cui, "The design and in addition evaluation of a cordless detecting unit organize for mine security following," in *Proc. IEEE GLOBECOM*, 2007, pp. 1230-1236.

[6] M. Li and in addition Y.- H. Liu, "Underground oal mine reconnaissance with cordless detecting unit systems," *ACM Trans. Sens. Netw.*, vol. 5