



## Fault Analysis of 3 Level And 5 Level with Induction Motor Drive

1U Chaithanya, 2K Kalyanchakravarthi, 3M Sriram swaroop, 4T Manoj kumar,

1Assistant Professor, 2,3,4B-tech student Scholar

1,2,3,4Department of Electrical & Electronics Engineering,

1,2,3,4 G. Pullaiah College of Engineering and Technology, Nandikotkur Rd,  
near Venkayapalle, Pasupula Village, Kurnool, Andhra Pradesh 518002

**Abstract:** In this project Fault analysis of 3 level and 5 level with Induction motor Drive is presented. Introduction motors are widely used in industrial applications for their intrinsic ruggedness and reduced cost. Recently, the use of adjustable speed drives has spread in many applications. Most of the industrial motors are used today are in fact induction motors. Induction motors have been used in the past mainly in applications requiring a constant speed because conventional methods of their speed control have either been expensive or highly inefficient. Multilevel inverters have a high number of switching states so that the output voltage is stepped in smaller increments. This allows mitigation of the harmonics at low switching frequencies thereby reducing switching losses. Almost 38% of faults in industrial loads like variable speed ac drive. IGBT's are used in almost all converters as power handling capability is high. It is estimated that among all types of faults in variable speed ac drives in industry, 10  $\mu$ s. The performance of the system analyzed by using MATLAB/SIMULINK software.

**Key words:** Diode clamped Inverter, Fault, Switch open and Switch short.

### I. INTRODUCTION

Majority of industrial drives use ac induction motor because these motors are rugged, reliable, and relatively and expensive. Induction motors are mainly used for constant speed applications because of unavailability of the variable frequency supply voltage but many applications need variable speed operations. Industrial applications have begun to require higher power apparatus in topical years. Some medium voltage motor drives and utility applications require medium voltage[1]. For a medium voltage grid, it is difficult to connect only one power semiconductor switch directly. As an outcome, a multilevel power converter structure has been introduced as an alternative in high power and medium voltage situations. The perception of multilevel converters has been introduced since 1975[2]. The main advantages of multilevel inverters include the increase of power, the diminution of voltage stress on the power switching devices, and the generation of high quality production voltages[3][4-8]. Multilevel converters are mainly utilized to synthesis a desired single or three-phase voltage waveform. The desired multi-staircase. The importance of multilevel inverters has been increased since last few decades. These new types of inverters are suitable for high voltage and high power application due to their ability to synthesize waveforms with better harmonic spectrum and with less THD. Plentiful techniques have been introduced and widely studied for utility of non conventional sources and also for drive

applications. The output voltage is obtained by combining several dc voltage sources[9].

An inverter convert DC power into AC power through waves called either sine waves or modified sine waves. A multilevel(MLI) uses a sequence of semiconductor power converters(usually two or three) thus generating higher voltage. While an inverter would have to flip several switches. An inverter is a device which receives dc supply for its input and produces ac output. A multilevel inverter is a more powerful inverter, in higher and medium voltage grid it is trouble to connect only one semiconductor switch directly, As a result multilevel inverter was introduced. A multilevel inverter is a power electronic device that is widely used in industries for high voltage and high power applications, with output harmonic content is reduced by using multilevel inverter (MLI)) One important application of multilevel converters is focused on medium and high-power conversion. Nowadays, there exist three commercial topologies of multilevel voltagesource inverters: neutral point clamped (NPC), cascaded H-bridge (CHB), and flying capacitors (FCs)[2]. Among these inverter topologies, diode multilevel inverter(MLI) reaches the higher output voltage and power levels and the higher reliability due to its modular topology[9][12][11]. Diode clamped inverter is the most commonly used multilevel topology, in which the diode is used as the clamping device to clamp the dc bus voltage so as to achieve steps in the output voltage. Nabae, Takahashi, and Akagi were proposed neutral point converter in 1981 it was essentially a three-level diodeclamped inverter [13].

## II. MULTI-LEVEL INVERTER

The system configuration of a motor drive using the Neutral point clamped inverter is shown in fig.1. This paragraph describes the operation of one of the legs shown at Fig.2. The voltage  $V_{ao}$  between the phase "a" and the neutral point O is defined entirely by the switches position (0 'open' or 1'closed'). Switch sets [Sa1, Sa3], and [Sa2, Sa4] have complementary positions. When [Sa1, Sa3] are open [Sa2, Sa4] are closed. The three-level NPC inverter is mostly used for medium-voltage high-power applications. In this converter, the number of commutation sequences (Seq) is equal to  $24 = 16$ . Where 4 stand for the number of switches per arm and 2 is the number of state per switch (0, 1).  $V_{dc}$  sequences are possible. Below shows the DC-busvoltage. Only three commutation configurations of their inverter's arm which correspond to the three possible commutation sequences:

- Sequence 1: Sa1, Sa2 conduct and Sa3, Sa4 open,  $V_{a0} = +V_{dc}/2$ .
- Sequence 2: Sa2, Sa3 conduct and Sa1, Sa4 open,  $V_{a0} = 0$ .
- Sequence 3: Sa3, Sa4 conduct and Sa1, Sa2 open,  $V_{a0} = -V_{dc}/2$ .

Sequences 1, 2 and 3 are applied in this order periodically.

A pulse width modulation is used to control the switches. In the motoring mode, power flows from the batteries through the Neutral point clamped inverter to the motor. In the charging mode, the Neutral point clamped converters act as rectifiers, and power flows from the charger to the batteries. The Neutral point clamped converter can also act as a rectifier to regenerate the kinetic energy of the vehicle if regenerative braking is used.

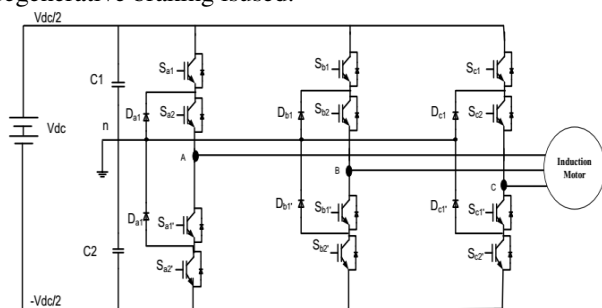

Fig.1. Neutral Point Clamped three level Inverter based Induction motor drive.

## III. FAULT ANALYSIS

Almost 38% of faults in industrial loads like variable speed ac drive. IGBT's are used in almost all converters as power handling capability is high. It is estimated that among all types of faults in variable speed

ac drives in industry, 10  $\mu$ s. But they suffer failures due to excess electrical and thermal stress that are experienced in many applications. IGBT failures can be broadly classified as diode open-faults, diode short-circuit faults, intermittent gate-misfiring faults, switch open and switch short fault.

**The short fault can occur with diode in short condition of switch Sa1.**

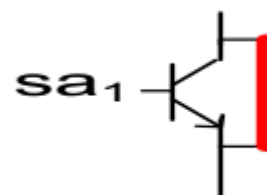

Fig.2. Shows the fault occurred due to the Diode in short condition.

**The open fault in switch Sa1 is introduced by opening the gate pulse**

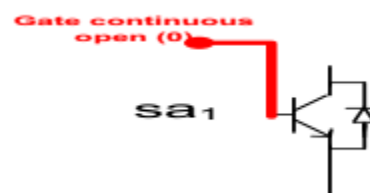

Fig.3. Shows the fault occurred due to the Gate in open condition.

**The short fault can occur with the gate in short condition of switch Sa1.**

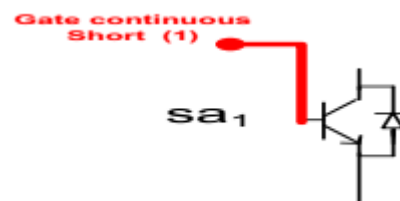

Fig.4. Shows the fault occurred due to the Gate in Short condition.

**An open-circuit fault in inverter is introduced by removing its IGBT.**



Fig.5. Shows the fault occurred due to the IGBT in open condition.

**The short-circuit fault in inverter is introduced by shorting the switch Sa1.**



Fig.6. Shows the fault occurred due to the IGBT in Short condition.

#### IV. DIODE-CLAMPED MULTILEVEL INVERTER

The most commonly used multilevel topology is the diode clamped inverter, in which the diode is used as the clamping device to clamp the dc bus voltage so as to achieve steps in the output voltage. The neutral point converter proposed by Nabae, Takahashi, and Akagi in 1981 was essentially a three-level diode-clamped inverter. A three-level diode clamped inverter consists of two pairs of switches and two diodes. Each switch pairs works in complimentary mode and the diodes used to provide access to mid-point voltage. In a three-level inverter each of the three phases of the inverter shares a common dc bus, which has been subdivided by two capacitors into three levels. The DC bus voltage is split into three voltage levels by using two series connections of DC capacitors, C1 and C2. The voltage stress across each switching device is limited to  $V_{dc}$  through the clamping diodes  $D_{c1}$  and  $D_{c2}$ . It is assumed that the total dc link voltage is  $V_{dc}$  and mid point is regulated at half of the dc link voltage, the voltage across each capacitor is  $V_{dc}/2$  ( $V_{c1}=V_{c2}=V_{dc}/2$ ). In a three level diode clamped inverter, there are three different possible switching states which apply the stair case voltage on output voltage relating to DC link capacitor voltage rate. For a three-level inverter, a set of two switches is on at any given time and in a five-level inverter, a set of four switches is on at any given time and so on. Fig.7 shows the circuit for a diode clamped inverter for a three-level and a five-level inverter.

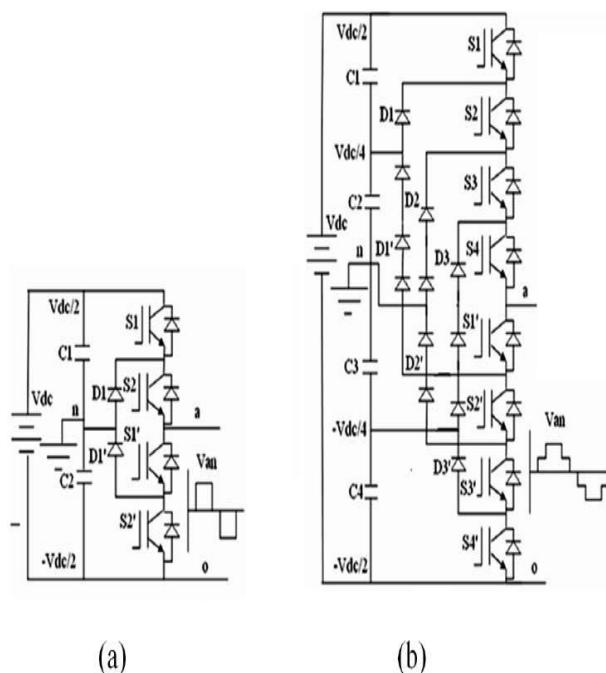

Fig.7 Topology of the diode-clamped inverter (a) three-level inverter, (b) five-level inverter

#### V. MATLAB/SIMULINK RESULTS

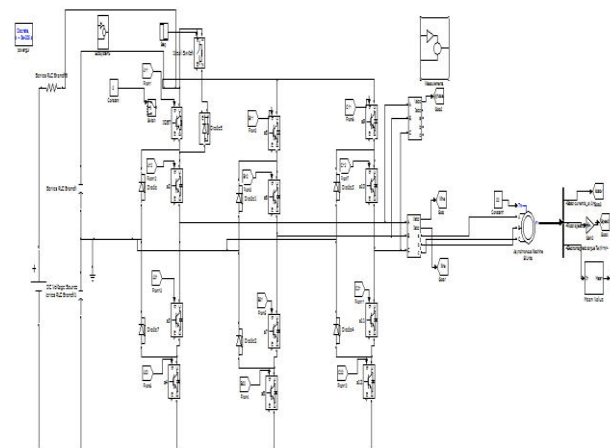

Fig.8. Simulink model of Three level inverter with Diode Open fault

#### Case 1: Analysis of Three Level Converter with "Diode Open" fault at Modulation Index= 1

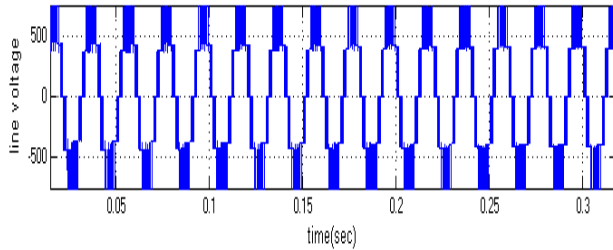

Fig.9. Simulated wave form of Line Voltage of the Inverter at MI=1 with Diode open fault

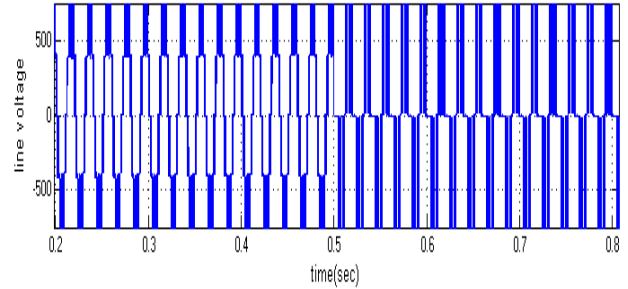

Fig.13. Simulated wave form of Line Voltage of the Inverter at MI=1 with Diode short fault.

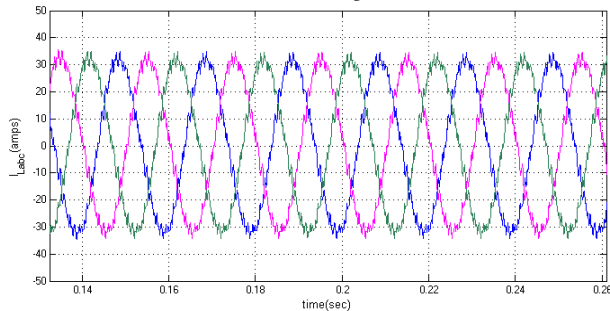

Fig.10. Simulated wave form of Line Current of the Inverter at MI=1 with Diode open fault.

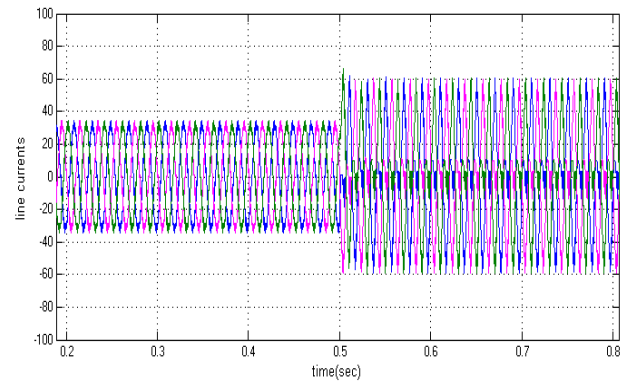

Fig.14. Simulated wave form of Line Current of the Inverter at MI=1 with Diode short fault.

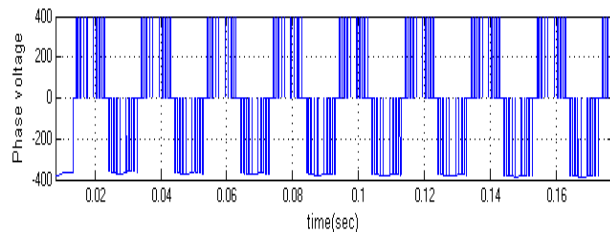

Fig.11. Simulated wave form of Phase voltage of the Inverter at MI=1 with Diode open fault.

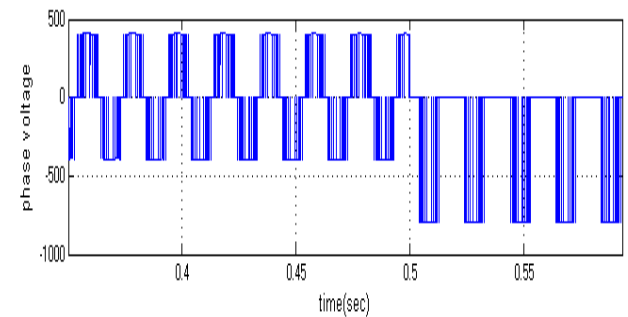

Fig.15. Simulated wave form of Phase voltage of the Inverter at MI=1 with Diode short fault.

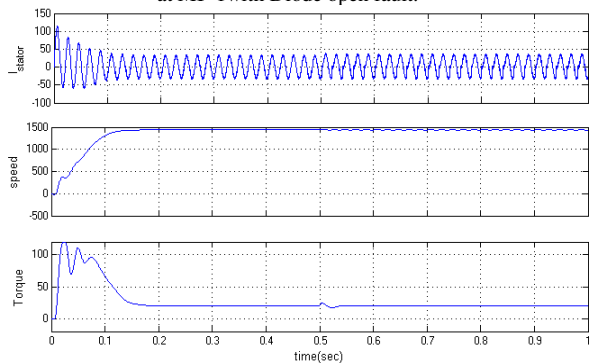

Fig.12. Performance characteristics of Current, Speed and Torque at MI=1 with Diode open fault.

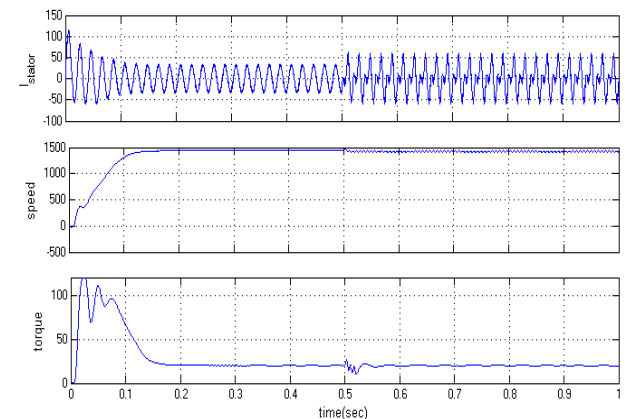

Fig.16. Performance characteristics of Current, Speed and Torque at MI=1 with Diode short fault.

## Case 2: Analysis of Three Level Converter with "Diode Short" fault at Modulation Index=1

### Case 3: Analysis of Three Level Converter with “Gate Open” fault at Modulation Index=1

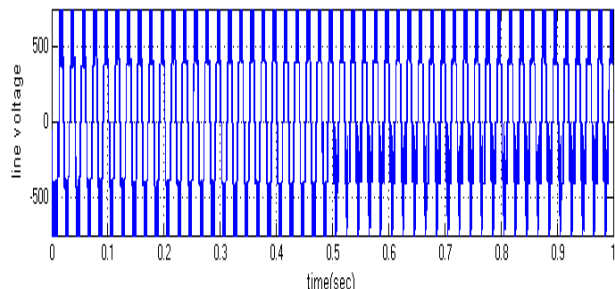

Fig. 17. Simulated wave form of Line Voltage of the Inverter at MI=1 with Gate open fault.

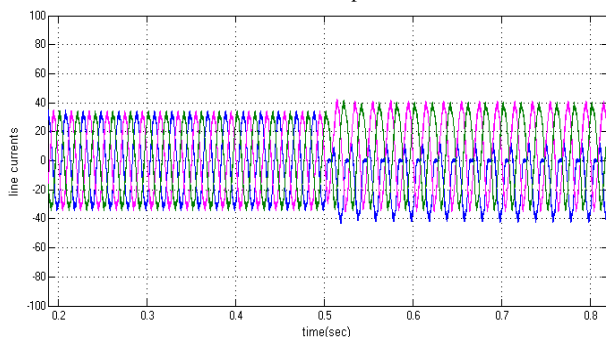

Fig. 18. Simulated wave form of Line Current of the Inverter at MI=1 with Gate open fault.

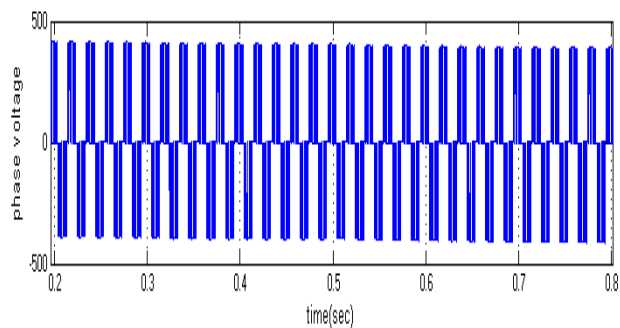

Fig. 19. Simulated wave form of Phase voltage of the Inverter at MI=1 with Gate open fault.

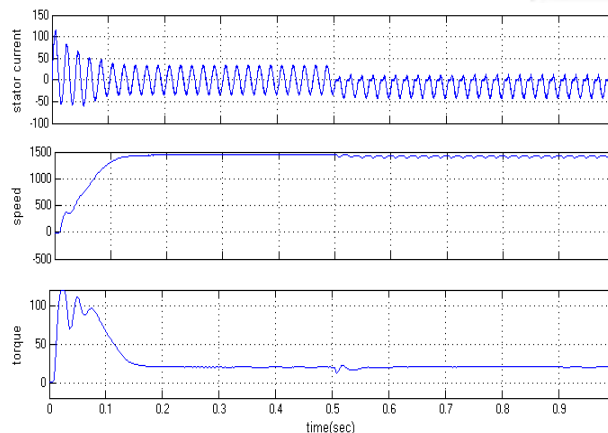

Fig. 20. Performance characteristics of Current, Speed and Torque at MI=1 with Gate open fault.

### Case 4: Analysis of Three Level Converter with “Gate Short” fault at MI= 1

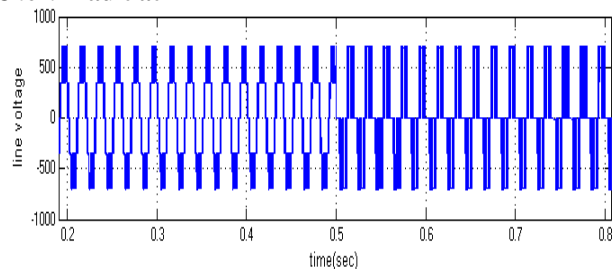

Fig. 21. Simulated wave form of Line Voltage of the Inverter at MI=1 with Gate short fault.

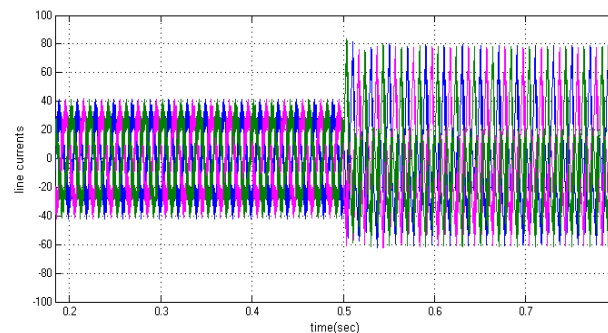

Fig. 22. Simulated wave form of Line Current of the Inverter at MI=1 with Gate short fault.

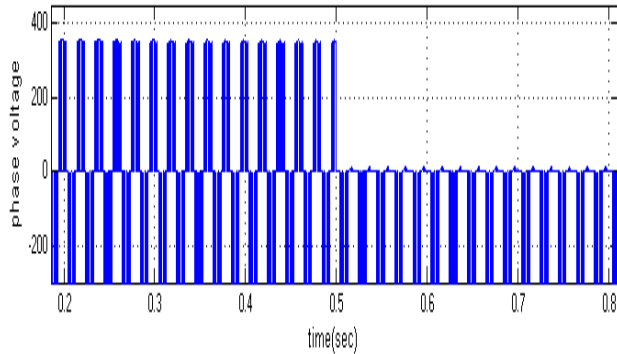

Fig.23. Simulated wave form of Phase voltage of the Inverter at MI=1 with Gate short fault.

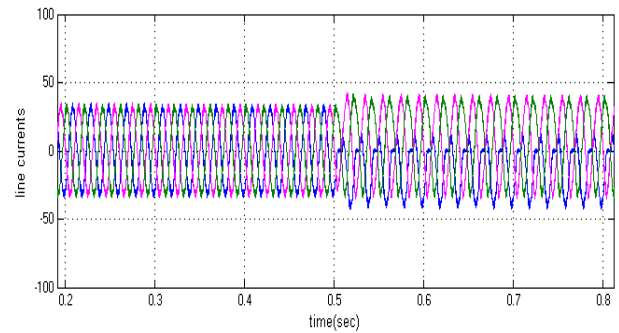

Fig.26. Simulated wave form of Line Current of the Inverter at MI=1 with Switch open fault.

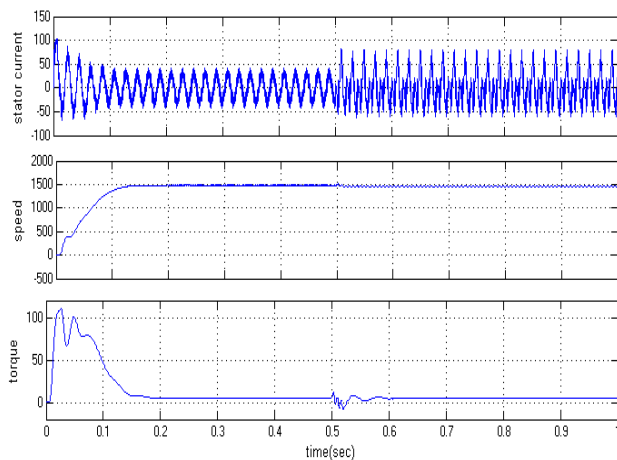

Fig.24. Performance characteristics of Current, Speed and Torque at MI=1 with Gate short fault.

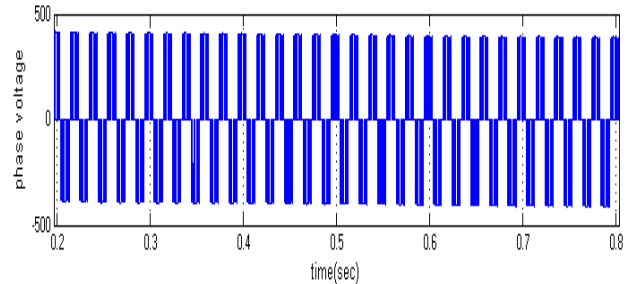

Fig.27. Simulated wave form of Phase voltage of the Inverter at MI=1 with Switch open fault.

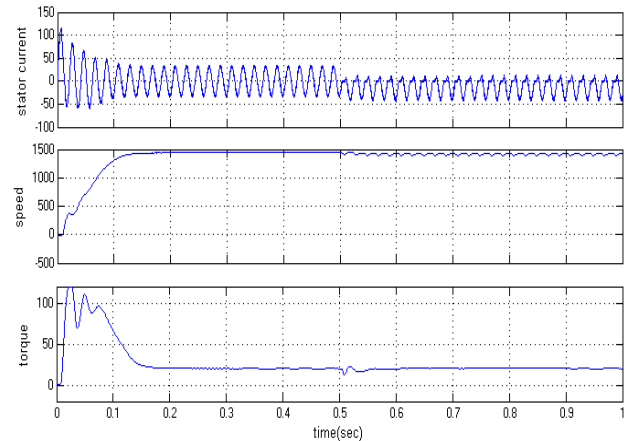

Fig.28. Performance characteristics of Current, Speed and Torque at MI=1 with Switch open fault.

### Case 5: Analysis of Three Level Converter with "Switch Open" fault at Modulation Index= 1

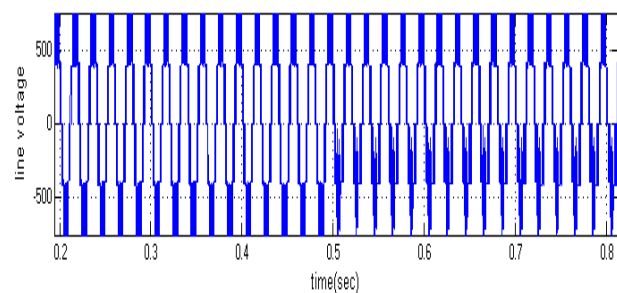

Fig.25. Simulated wave form of Line Voltage of the Inverter at MI=1 with Switch open fault.

### Case 6: Analysis of Three Level Converter with "Switch Short" fault at Modulation Index=1

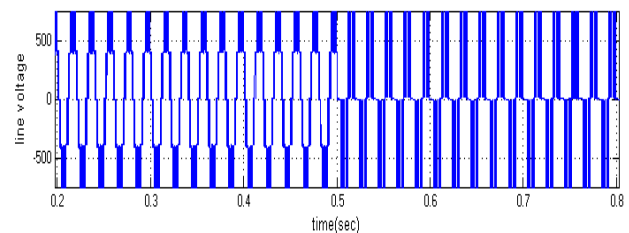

Fig.29. Simulated wave form of Line Voltage of the Inverter at MI=1 with Switch short fault.

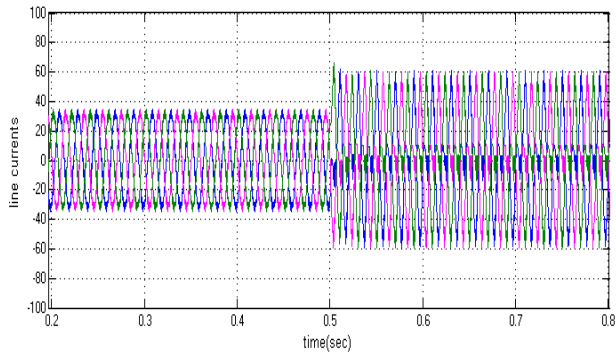

Fig.30. Simulated wave form of Line Current of the Inverter at MI=1 with Switch short fault.

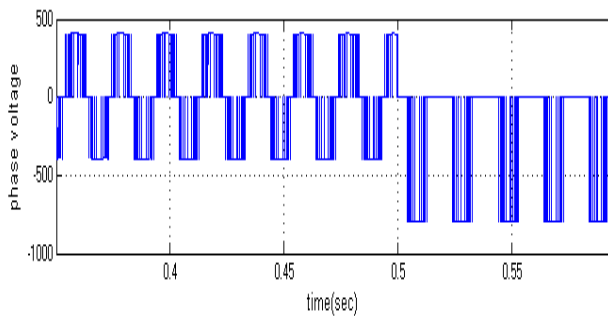

Fig.31. Simulated wave form of Phase voltage of the Inverter at MI=1 with Switch short fault.

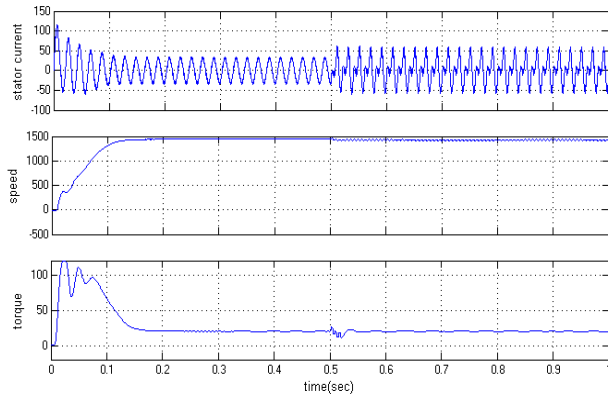

Fig.32. Performance characteristics of Current, Speed and Torque at MI=1 with Switch short fault.

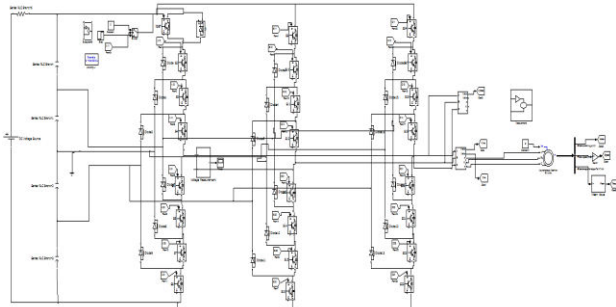

Fig.33. Simulink model of Five level inverter with Switch open fault

## Case 7: Analysis of Three Level Converter with “Switch Open” fault at Modulation Index=1

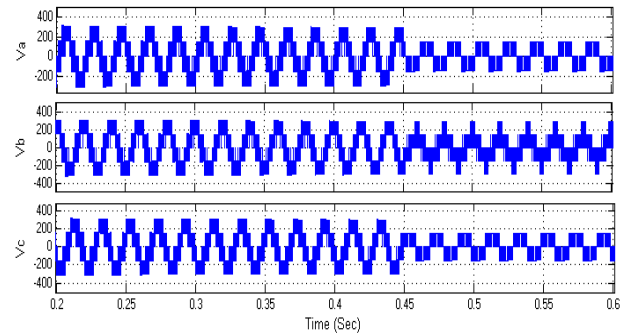

Fig.34. Simulated wave form of Line Voltage of the Inverter at MI=1 with Switch open fault.

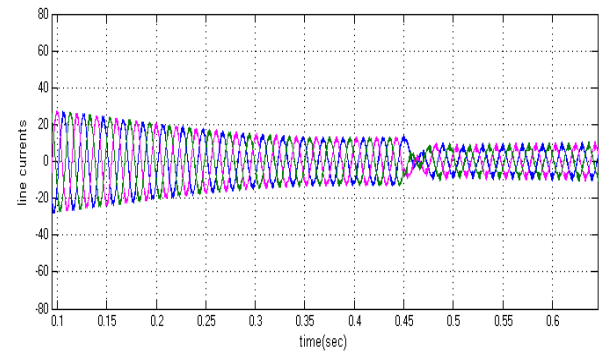

Fig.35. Simulated wave form of Line Current of the Inverter at MI=1 with Switch open fault.

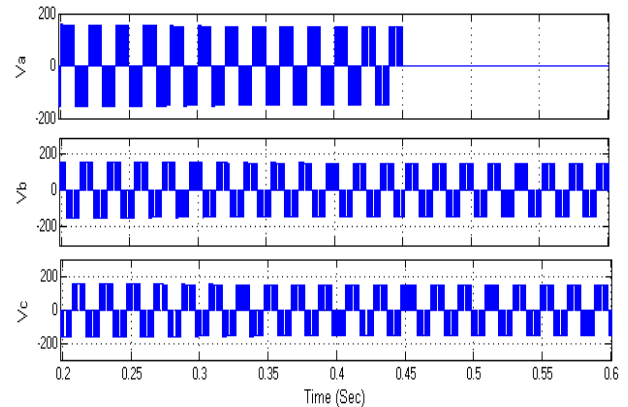

Fig.36. Simulated wave form of Phase voltage of the Inverter at MI=1 with Switch open fault.

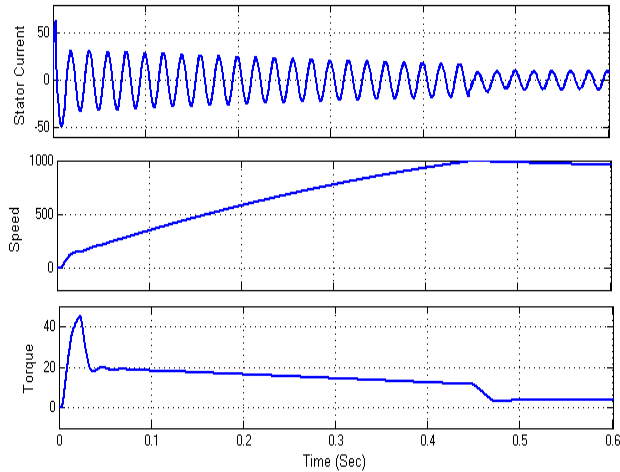

Fig.37. Performance characteristics of Current, Speed and Torque at MI=1 with Switch open fault.

### Case 8: Analysis of Three Level Converter with “Switch Short” fault at Modulation Index=1

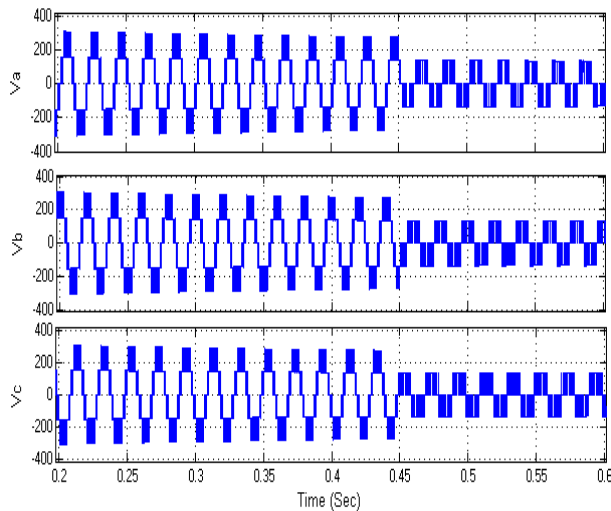

Fig.38. Simulated wave form of Line Voltage of the Inverter at MI=1 with Switch Short fault.

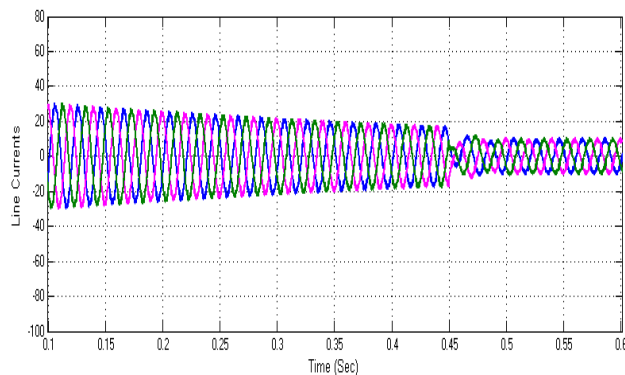

Fig.39. Simulated wave form of Line Current of the Inverter at MI=1 with Switch Short fault.

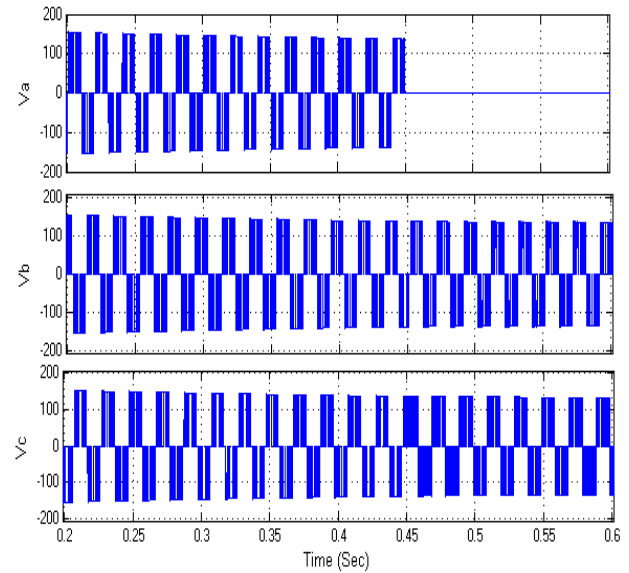

Fig.40. Simulated wave form of Phase voltage of the Inverter at MI=1 with Switch Short fault.

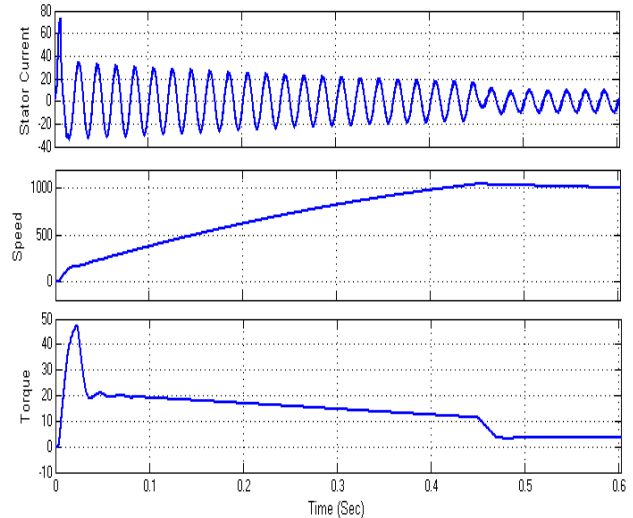

Fig.41. Performance characteristics of Current, Speed and Torque at MI=1 with Switch Short fault.

## VI. CONCLUSION

In this work the simulation results of three phase three level diode clamped multilevel inverter fed Induction Motor load with modulating strategy are obtained through MATLAB/SIMULINK. The simulation result shows that the harmonics have been reduced considerably. The three level and Five level inverter fed induction motor system has been successfully simulated. The diode-clamped inverter provides multiple voltage levels through connection of the phases to a series of capacitors. Early descriptions of this topology were limited to three-levels where two capacitors are connected across the dc bus resulting in one additional level. The





output quantities like phase voltage and line voltage, THD spectrum for phase voltage and line voltage and torque, rotor current, stator current characteristics of induction motor are obtained.

## REFERENCES

- [1]. F. W. Fuchs, "Some diagnosis methods for voltage source inverters in variable speed drives with induction machines—A survey," in Proc. IEEE Ind. Electron. Conf., 2003, pp. 1378–1385.
- [2]. K. Rothenhagen and F. W. Fuchs, "Performance of diagnosis methods for IGBT open circuit faults in voltage source active rectifiers," IEEE PES Proc., 2004, pp. 4348–4354.
- [3]. M. S. Mendes, A. J. M. Cardoso, and E. S. Saraiva, "Voltage source inverter fault diagnosis in variable speed AC drives, by the average current Park's vector approach," IEEE IEMDC Proc., 1999, pp. 704–706.
- [4]. R. L. A. Ribeiro, C. B. Jacobina, E. R. C. Silva, and A. M. N. Lima, "Fault detection of open switch damage in voltage-fed PWM motor drive systems," IEEE Trans. Power Electron., vol. 18, no. 2, pp. 587–593, Mar. 2003.
- [5]. Kral and K. Kafka, "Power electronics monitoring for a controlled voltage source inverter drive with induction machines," in Proc. IEEE 31st Annu. Power Electron. Spec. Conf., 2000, vol. 1, pp. 213–217.
- [6]. Diallo, M. E. H. Benbouzid, D. Hamad, and X. Pierre, "Fault detection and diagnosis in an induction machine drive: a pattern recognition approach based on Concordia stator mean current vector," IEEE Trans. Energy Conv., vol. 20, no. 3, pp. 512–519, Sept. 2005.
- [7]. O. V. Thorsen and M. Dalva, "A survey of the reliability with an analysis of faults on the variable frequency drives in industry," in Proc. Conf. Rec. 6th Eur. Power Electron. Appl. Conf., Sevilla, Spain, 1995, pp. 1033–1038.
- [8]. H. Schwab, A. Kl'onne, S. Reck, and I. Ramesohl, "Reliability evaluation of a permanent magnet synchronous motor drive for an automotive application," in Proc. Conf. Rec. Eur. Power Electron. Appl., Toulouse, France, 2003.
- [9]. UTE C 20-810 RDF 2000, Reliability Data Handbook, Union technique de L'Electricite, Jul. 2000.
- [10]. B. A. Welchko, T. A. Lipo, T. M. Jahns, and S. E. Schulz, "Fault tolerant three-phase ac motor drive topologies: A comparison of features, cost, and limitations," IEEE Trans. Power Electron., vol. 19, no. 4, pp. 1108–1116, Jul. 2004.
- [11]. T. H. Liu, J. R. Fu, and T. A. Lipo, "A strategy for improving reliability of field oriented controlled induction motor drives," IEEE Trans. Ind. Appl., vol. 29, no. 5, pp. 910–918, Sep./Oct. 1993.
- [12]. M. Villani, M. Tursini, G. Fabri and L. Castellini, "Multiphase Fault Tolerant Drives for Aircraft Applications," in Electrical Systems for Aircraft, Railway and Ship Propulsion (ESARS2010), 2010.
- [13]. J. Zhu, H. Zhang, R. Tang, "The Study and Modeling of Multi-Phase PMSM Variety Speed System with High Fault Tolerant," in International Conference on Electrical Machines and Systems (ICEMS 2008), 2008.