



ANALYSIS OF A PHASE-SHIFT-CONTROLLED ACTIVE BOOST RECTIFIER FOR SOFT-SWITCHING DC-DC CONVERTERS

Dr. Rajsvelan. C, Ms. S Rodavishal, Mr. R. Ranadher Reddy

¹Associate professors, Department of EEE ,Balaji Institute of Technology and science.

²Assistant professors. Department of EEE, Balaji Institute of Technology and science.

ABSTRACT

High efficiency and high power density can be achieved with a dc–dc transformer by operating all the switches at a fixed 50% duty cycle. However, the output voltage of the dc–dc transformer cannot be regulated. Novel rectifiers named active boost rectifiers (ABRs) are proposed in this paper. Basically, an ABR is composed of a traditional diode rectifier and a bidirectional switch. By adopting phase-shift control between the primary- and secondary-side switches, the output voltage regulation can be achieved when introducing the ABR to a dc–dc transformer. As a result, a family of novel soft-switching dc–dc converters is harvested. When the proposed converter operates in the soft-switching continuous conduction mode, zero-voltage switching (ZVS) performance for all the primary- and secondary side switches is achieved. When the converter operates in the discontinuous conduction mode, zero current switching (ZCS) for the primary-side switches and ZVS for the secondary-side switches are achieved. By receiving stage shift control between the essential and optional side switches, the yield voltage direction can be accomplished while acquainting the ABR with a dc–dc transformer. Subsequently, a group of novel delicate exchanging dc–dc converters is gathered. At the point when the proposed converter works in the delicate exchanging ceaseless conduction mode, zero-voltage exchanging (ZVS) execution for all the essential and optional side switches is accomplished. At the point when the converter works in the inconsistent conduction mode, zero current exchanging (ZCS) for the essential side switches and ZVS for the optional side switches are accomplished.

1. INTRODUCTION

WITH rapid developments of renewable energy, smart grid, and electric vehicles, isolated dc–dc converters have been widely used in a number of applications to meet the requirements of galvanic isolation and/or voltage conversion ratio [1], [2]. For further improvements on performance of efficiency, power density, and electromagnetic noise, many soft-switching dc–dc converters have been proposed for various applications to overcome the disadvantages in hard-switching dc–dc converters [3]. Among them, the phase-shift fullbridge converter (FBC) is more attractive because it can achieve zero voltage switching (ZVS) for all the active switches by adopting phase-shift modulation. However, until now, it still suffers from high voltage ringing

and reverse recovery on the secondary-side rectifier diodes, limited ZVS range, circulating current-related power loss, and duty cycle loss. The reverserecovery problem of the rectifier diodes becomes even more serious in high-output voltage and high-power applications. Various improvements have been proposed to solve these problems.

Generally, some additional components are introduced to suppress the circulating currents and alleviate the reverse-recovery problem. For instance, an auxiliary inductor, a transformer, or a winding is introduced to recycle the energy in [6]. In [5], two active switches are introduced to the secondary-side rectifier to solve the reverse-recovery problem, but the penalty is an additional conduction loss. Recently, the dual active bridge topology



attracts great interest because it can realize ZVS for all the power switches [6]. But the limited ZVS range and high circulating currents at light load make this converter unsuitable for wide voltage/load range applications. Another attractive solution for the isolated dc–dc power conversion is the *LLC* resonant converter. By designing and selecting a proper operation region, soft switching of all the active switches and rectifier diodes over a wide load range can be achieved with the *LLC* resonant converter. However, frequency modulation makes the accurate modeling of the *LLC* converter difficult to achieve, and also complicates the design of magnetic components. Besides, the resonant tank in the *LLC* converter should be designed carefully as well to achieve high efficiency, which remains a challenge for this type of converter.

DC-DC converters are important in most of the portable electronic devices and are employed in variety of applications including supply for personal computers, office equipment, spacecraft power systems, laptops, telecommunication equipment's as well as DC motor drives which are very much useful to people . With rapid developments of renewable energy, smart grid, and electric vehicles, isolated dc–dc converters have been widely used in a number of applications to meet the requirements of galvanic isolation and/or voltage conversion ratio. For further improvements on performance of efficiency, power density, and electromagnetic noise, many soft-switching dc–dc converters have been proposed for various applications to overcome the disadvantages in hard-switching dc–dc converters. Among them, the phase-shift full bridge converter (FBC) is more attractive because it can achieve zero voltage switching (ZVS) for all the active switches by adopting phase-shift modulation. However, until now, it still suffers from high voltage ringing and reverse recovery on the secondary-side rectifier diodes, limited ZVS range, circulating current-related power loss, and duty cycle loss. Consequently, high productivity and high power density can be effectively accomplished. In any case, the yield

voltage/force of a dc–dc transformer can't be managed. In the event that the yield voltage of a dc–dc transformer can be managed, high proficiency might be effortlessly accomplished. To accomplish the objective specified already, this paper proposes the dynamic support rectifier (ABR) idea. The ABR circuit is acquainted with the dc–dc transformer topology to actualize yield voltage/power direction. Accordingly, a group of widerange delicate exchanging detached dc–converters is gathered. The significant preferred standpoint of the proposed converters is that the ZVS for all the dynamic switches can be accomplished in a wide load range.

2. PROPOSED DC-DC CONVERTER

1. Working of an ABR

The obligation cycles of all the switches are altered at 0.5. The voltage-source full-connect inverter, which is made out of a dc info voltage source U_{in} and four switches $S_1 - S_4$, creates an air conditioner square-wave voltage u_p , applying to the essential twisting of the transformer. Hence, the converter appeared in Fig. 1 can be spoken to by the one appeared in Fig. 2(a). For straightforwardness, considering a perfect transformer T with turns a proportion of 1, this circuit can be further rearranged to an uncontrolled rectifier, as appeared in Fig. 2(b). Clearly the yield voltage can't be directed if the obligation cycles of all the switches are settled at 0.5.

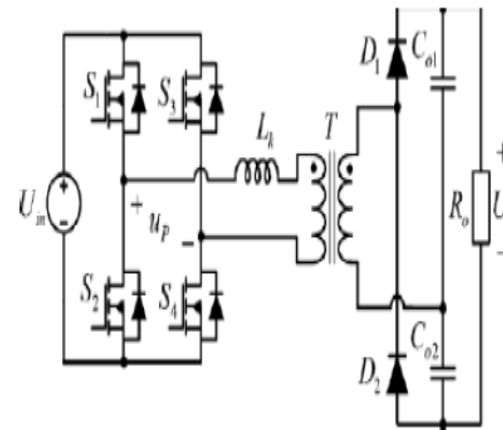

Fig. 1. Topology of a full-bridge converter with voltage-doubler rectifier.

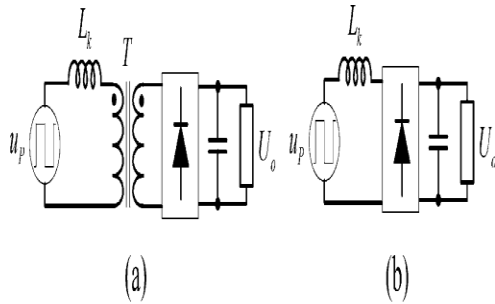

Fig. 2. Simplified circuits of the full-bridge converter shown in Fig. 1: (a) including the transformer and (b) excluding the transformer.

Family of DC-DC Converters Based on ABR

1) *Circuits of ABR:* In the analysis aforementioned, an ABR circuit has been derived based on a conventional VD diode rectifier. This concept can also be applied to the conventional full-bridge and full-wave diode rectifiers, as shown in Fig. 3. It should be noted that, as shown in Fig. 3(b), because the transformer has two secondary windings, two unidirectional switches S_{u1} and S_{u2} , instead of one bidirectional switch, are introduced to build an ABR. A bidirectional switch can be realized through the combination of MOSFETs and diodes, while a unidirectional switch can be realized through a series connection of a MOSFET and a diode. Some possible realizations of the bidirectional and unidirectional switches are illustrated in Fig. 4. Based on these switches, a family of ABR circuits can be derived. Some example topologies are shown in Fig. 5. On the other hand, for the full-bridge diode rectifier, a bidirectional switch which is paralleled with the transformer winding can also be built by replacing the two diodes in the rectifier with two MOSFETs. As a result, simplified full-bridge ABR topologies can be derived and shown in Fig. 8, where the bidirectional switches have been highlighted with red color. It is obvious that two diodes can be reduced compared to the Fig. 5(b).

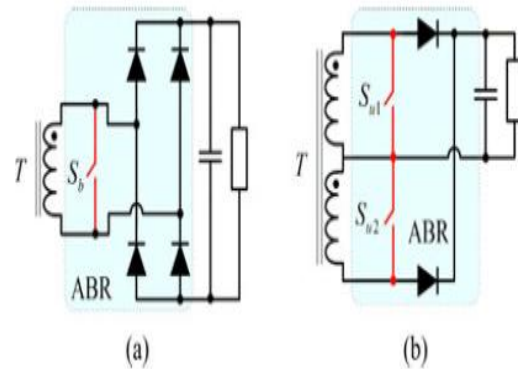

Fig. 3. Topologies of ABR derived from (a) full-bridge and (b) center-tapped diode-rectifiers.

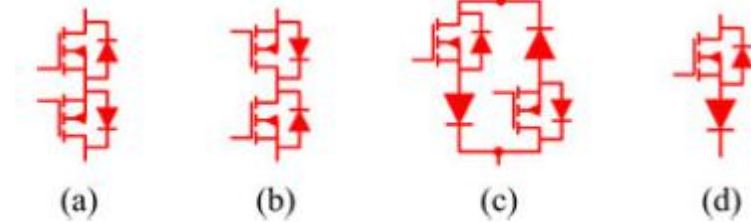

Fig. 4. (a)–(c) Realizations of bidirectional switch and (d) unidirectional switch.

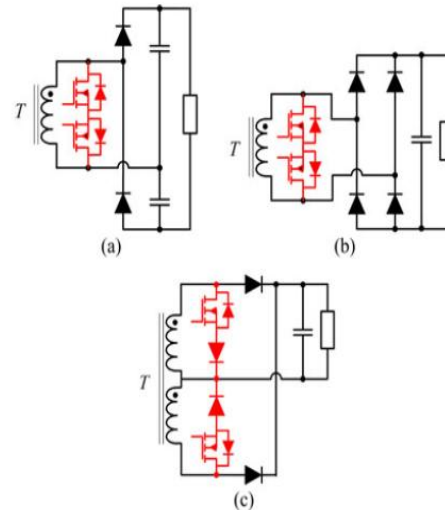

Fig. 5. Derived ABR topologies: (a) voltage-doubler, (b) full-bridge, and (c) center-tapped.

3. ANALYSIS ON THE FBC WITH VOLTAGE-DOUBLER ABR

One of the proposed topology, the FBC with VD ABR, is taken as an example to be analyzed in this section to verify the feasibility of the proposed topologies.

A. Operational Principle



The FBC-VD-ABR is redrawn in Fig. 7, where all the switches on the primary and secondary sides have a constant duty cycle of 0.5. S_1 and S_4 are always turned-ON/OFF simultaneously, and the same with S_2 and S_3 . A phase-shift angle between the primary- and secondary-side active switches is employed to regulate the output power and voltage. L_f stands for the total of the transformer leakage inductance and external inductor.

The output series capacitors C_{o1} and C_{o2} have the same capacitance and are large enough to clamp the voltage stresses of the secondary-side switches and diodes to half of the output voltage. u_{DS1} , u_{DS4} , and u_{DS6} are the drain to source voltages of S_1 , S_4 , and S_6 , respectively. u_P and u_S are the voltages on the primary side and secondary side of the transformer. And i_{Lf} is the primary current flowing through the transformer with the positive direction shown in Fig. 7. A proper dead time is necessary for the primary-side switches to achieve ZVS and avoid shoot-through of the switching bridges. To simplify the analysis, the parasitic capacitance of MOSFET is ignored and

the transformer is assumed to be ideal.

The normalized voltage gain G is defined as

$$G = \frac{NU_o}{2U_{in}}$$

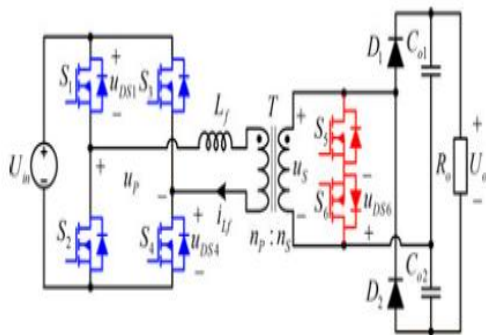

Fig. 7. Proposed full-bridge converter with voltage-doubler active boost rectifier.

According to the waveforms of the primary-side current, the converter has three operation

modes, namely secondary-side soft-switching continuous-conduction mode (SS-CCM), secondary-side hard-switching continuous-conduction mode (HS-CCM), and discontinuous conduction mode (DCM), respectively.

CONCLUSION

In this paper, a family of soft-switching dc-dc converters has been presented for high-efficiency applications based on the novel proposed ABRs. In the proposed converters, all the power switches are operated at fixed 50% duty cycle, and the output voltage regulation is achieved by adopting phase-shift control between the primary and secondary-side switches. ZVS performance has been achieved for both the primary and secondary-side switches in a wide voltage and load range. Furthermore, the reverse-recovery problems associated with the rectifier diodes are alleviated. Therefore, the switching losses of the proposed converters can be reduced, which is important for high-frequency, high-efficiency, and high-power density applications. Moreover, the leakage inductance of the transformer has been utilized as the energy transfer inductor, and all the devices voltages are clamped to the input or output voltage. Thus, the voltage overshoots on the devices are effectively suppressed. In addition, the proposed converters are suitable for wide-range applications because they can operate either in Buck or Boost mode. As an example, the FBC with VD ABR is analyzed with operation principles and output characteristics presented. Experimental results of a 1 kW prototype have verified the feasibility and effectiveness of the proposed topological methodology and converters.

REFERENCES

- [1] Choo, B., H., Lee, D., Y., Yoo, S., B., Hyun, D., S.: A Novel Full-Bridge ZVZCS PWM DC/DC Converter with a Secondary Clamping Circuit. PESC'98, Fukuoka, Japan, pp. 936-941
- [2] Lee, D. Y., Lee, B., K., Hyun, D. S.: A Novel Full-Bridge Zero-Voltage-Transition PWM DC/DC Converter with Zero-Voltage/Zero-Current Switching of Auxiliary



- Switches. PESC'98, Fukuoka, Japan, pp. 961-968
- [3] Dudrik, J., Dzurko, P.: An Improved Soft-Switching Phase-Shifted PWM Full-Bridge DC-DC Converter. PEMC 2000, Košice, 2000, pp. 2/65-69
- [4] Dudrik, J., Dzurko, P.: Arc-Welding Using Soft-Switching Phase-Shifted PWM Full-Bridge DC-DC Converter. Proc. of the Int. Conf. on Electrical Drives and Power Electronics, 1999, High Tatras, pp. 392-396
- [5] Dudrik, J., Dzurko, P.: Modern Voltage and Current Power Supplies. Proc. of the Int. Conf. EDPE'99, Industry Day, 1999, High Tatras, pp. 46-51 (In Slovak)
- [6] Dudrik, J.: Current-Mode Controlled DC Source for Arc Welding, EPEPEMC 2004, Riga, Latvia, 2004, pp. 5-203-5-207 – CD Rom
- [7] Dudrik, J.: Circuits for Decreasing of Switching Losses in Extreme Conditions of the Converter. Slovak patent No. 283721, 2003