

DYNAMIC VOLTAGE RESTORER AS POWER QUALITY CUSTOM POWER DEVICE

Mr Siva Prasad, Dr Rahul Wilson

Assistant professor, Department of Electrical & Electronics Engineering, Malla Reddy
Engineering College For Women(Autonomous Institution)

Associate Professor, Department of Electrical and Electronics Engineering, Malla Reddy
Engineering College For Women(Autonomous Institution)

ABSTRACT

Power Quality is an essential concern in the modern power system that can affect consumers and utility. The integration of renewable energy sources, smart grid systems and extensive use of power electronics equipment caused myriad problems in the modern electric power system. Current and voltage harmonics, voltage sag, and swell can damage the sensitive equipment. These devices are susceptible to input voltage variations created by interference with other parts of the system. Hence, in the modern age, with an increase in sensitive and expensive electronic equipment, power quality is essential for the power system's reliable and safe operation. Dynamic Voltage Restorer (DVR) is a potential Distribution Flexible AC Transmission System (D-FACTS) device widely adopted to surmount the problems of non-standard voltage, current, or frequency in the distribution grid. It injects voltages in the distribution line to maintain the voltage profile and assures constant load voltage. The simulations were conducted in MATLAB/Simulink to show the DVR-based proposed strategy's effectiveness to smooth the distorted voltage due to harmonics. A power system model with a programmable power source is used to include 3rd and 5th harmonics. The systems' response for load voltage is evaluated for with and without DVR scenarios. It has been noted that the proposed DVR based strategy has effectively managed the voltage distortion, and a smooth compensated load voltage was achieved. The load voltage THD percentage was approximately 18% and 23% with insertion 3rd and 5th harmonics in the supply voltage, respectively. The inclusion of the proposed DVR has reduced THD around less than 4% in both cases.

Keywords: Power Quality, Modern Power System, Renewable Energy Sources, Smart Grid Systems, Power Electronics Equipment, Current Harmonics, Voltage Harmonics, Voltage Sag, Voltage Swell, Sensitive Equipment, Input Voltage Variations, Dynamic Voltage Restorer (DVR), Total Harmonic Distortion (THD)

INTRODUCTION

In the contemporary landscape of power systems, the quest for maintaining optimal power quality has become paramount, driven by the integration of renewable energy sources, the advent of smart grid systems, and the widespread deployment of power electronics equipment. These advancements have ushered in a new era of electricity generation, transmission, and distribution,

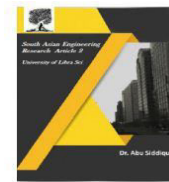

offering both opportunities and challenges for ensuring the reliability and efficiency of the power supply [1-3]. Power quality encompasses a multitude of factors that can influence the performance of electrical networks and the equipment connected to them. Among these factors, current and voltage harmonics, voltage sag, voltage swell, and input voltage variations stand out as critical parameters that require meticulous attention [4]. The presence of harmonics, for instance, can distort the sinusoidal waveform of the voltage and current signals, leading to detrimental effects on the performance of sensitive equipment such as computers, medical devices, and industrial machinery [5].

Voltage sags and swells, on the other hand, refer to temporary reductions or increases in the magnitude of the voltage levels, often caused by abrupt changes in the electrical load or faults in the distribution system [6]. These voltage deviations can disrupt the operation of sensitive equipment, cause malfunctions, and incur significant financial losses for industrial and commercial consumers [7]. Moreover, the integration of renewable energy sources such as solar photovoltaics and wind turbines into the grid introduces additional complexities to the power system dynamics. The intermittency and variability of renewable generation pose challenges for maintaining grid stability and power quality, necessitating innovative solutions for grid management and control [8]. In this context, the concept of the Dynamic Voltage Restorer (DVR) has emerged as a promising technology for addressing power quality issues at the distribution level. The DVR belongs to the family of Distribution Flexible AC Transmission System (D-FACTS) devices and is designed to mitigate voltage disturbances and improve power quality in distribution networks [9]. By actively injecting compensating voltages into the distribution line, the DVR can mitigate voltage sags, swells, and harmonics, thereby ensuring a stable and reliable power supply to sensitive loads [10].

The integration of DVRs into distribution grids offers several benefits, including improved voltage profile, enhanced reliability, and increased system resilience against voltage fluctuations and disturbances [11]. By providing dynamic voltage support, DVRs enable the continuous operation of critical loads, thereby minimizing downtime and maximizing productivity in various industrial, commercial, and residential applications [12]. To evaluate the effectiveness of DVRs in enhancing power quality, extensive research and development efforts have been undertaken, encompassing theoretical analyses, simulation studies, and experimental validations [13]. Advanced simulation tools such as MATLAB/Simulink have facilitated the modeling and analysis of power systems with DVR integration, allowing researchers to assess the performance of DVR-based control strategies under different operating conditions [14].

Simulation studies have demonstrated the efficacy of DVR-based solutions in mitigating voltage distortions caused by harmonics and other power quality issues [15]. By implementing sophisticated control algorithms, DVRs can dynamically adjust the injected voltages to maintain a smooth and stable load voltage profile, thereby minimizing the impact of voltage fluctuations on sensitive equipment and improving overall system performance. In summary, the Dynamic Voltage

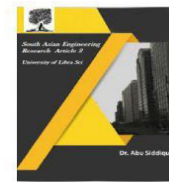

Restorer (DVR) represents a promising custom power device for enhancing power quality and ensuring the reliable operation of electrical networks in the modern power system. By mitigating voltage disturbances, harmonics, and other power quality issues, DVRs contribute to the optimization of grid performance, the reduction of downtime, and the enhancement of overall system reliability and efficiency.

LITERATURE SURVEY

The pursuit of reliable and high-quality power supply is a fundamental objective in modern power systems, where the integration of renewable energy sources, advancements in smart grid systems, and the widespread utilization of power electronics equipment have ushered in a new era of electricity generation, transmission, and distribution. However, amidst these advancements lies the pressing concern of power quality, encompassing a multitude of factors that can profoundly impact the performance of electrical networks and the equipment connected to them. One of the primary challenges in ensuring power quality is the presence of current and voltage harmonics, which can distort the sinusoidal waveform of voltage and current signals. Harmonics arise from the operation of nonlinear loads such as power electronics equipment, leading to undesirable effects such as increased losses, reduced efficiency, and overheating of equipment. Voltage sag and swell are additional phenomena that can disrupt the operation of sensitive equipment. Voltage sag refers to a temporary reduction in voltage levels, often caused by sudden increases in load demand or faults in the distribution system, while voltage swell involves temporary increases in voltage levels. The proliferation of sensitive electronic equipment across various sectors, including industrial, commercial, and residential settings, underscores the critical importance of mitigating power quality issues. Sensitive equipment such as computers, medical devices, and industrial machinery are highly susceptible to voltage fluctuations and harmonics, which can lead to malfunctions, reduced lifespan, and significant financial losses.

In addressing power quality concerns, the Dynamic Voltage Restorer (DVR) has emerged as a promising technology for improving voltage stability and mitigating voltage disturbances in distribution networks. As a member of the Distribution Flexible AC Transmission System (D-FACTS) family, DVRs are designed to inject precise compensating voltages into the distribution line, thereby counteracting voltage sags, swells, and harmonics. By maintaining a stable voltage profile and ensuring a constant load voltage, DVRs play a crucial role in safeguarding sensitive equipment from voltage fluctuations and disturbances. The effectiveness of DVRs in enhancing power quality has been extensively studied through theoretical analyses, simulation studies, and experimental validations. Simulation tools such as MATLAB/Simulink provide a versatile platform for modeling and analyzing power systems with DVR integration. Simulation studies have demonstrated the capability of DVR-based solutions to mitigate voltage distortions and ensure a smooth load voltage profile under various operating conditions. These studies have contributed valuable insights into the performance characteristics and control strategies of DVRs, paving the way for their widespread deployment in distribution networks. Experimental validations have further corroborated the effectiveness of DVRs in real-world settings, providing empirical

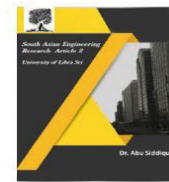

evidence of their ability to improve power quality and protect sensitive equipment from voltage disturbances. By conducting experiments in controlled laboratory environments and field installations, researchers have gained valuable data on the performance, reliability, and operational characteristics of DVRs.

Despite their potential benefits, the integration of DVRs into distribution networks poses several challenges, including control coordination, system compatibility, and cost considerations. Addressing these challenges is crucial for ensuring the successful deployment and operation of DVRs as custom power devices for power quality improvement. Comparative studies have been conducted to evaluate the performance of DVRs against other power quality improvement devices such as static compensators (STATCOMs) and active power filters (APFs). These studies have highlighted the unique advantages of DVRs in mitigating voltage disturbances and improving power quality in distribution networks. By analyzing the performance, cost-effectiveness, and scalability of different power quality improvement solutions, researchers can identify the most suitable technologies for specific applications and deployment scenarios.

Looking ahead, future research in the field of DVRs and power quality improvement may focus on developing advanced control algorithms, optimizing DVR performance in multi-source microgrids, and addressing integration challenges in distribution networks. By leveraging advancements in control theory, communication technologies, and renewable energy integration, researchers can further enhance the effectiveness and reliability of DVRs as custom power devices for enhancing power quality in modern power systems. The Dynamic Voltage Restorer (DVR) represents a promising solution for improving power quality and ensuring the reliable operation of sensitive equipment in distribution networks. Through theoretical analyses, simulation studies, experimental validations, and comparative assessments, researchers have demonstrated the effectiveness of DVRs in mitigating voltage disturbances and harmonics, thereby contributing to the optimization of power system performance and the enhancement of overall grid reliability and efficiency.

PROPOSED SYSTEM

In the contemporary landscape of power systems, ensuring optimal power quality has become an indispensable concern amidst the integration of renewable energy sources, advancements in smart grid systems, and the widespread deployment of power electronics equipment. Power quality encompasses a range of factors, including current and voltage harmonics, voltage sag, voltage swell, and input voltage variations, all of which can significantly affect the performance and reliability of electrical networks and the equipment connected to them. The proliferation of sensitive electronic equipment across various sectors, including industrial, commercial, and residential settings, highlights the critical importance of mitigating power quality issues to prevent equipment damage, ensure uninterrupted operations, and minimize financial losses. Voltage fluctuations, harmonics, and other power quality disturbances can lead to malfunctions, reduced

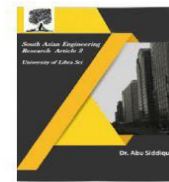

efficiency, and increased wear and tear on equipment, ultimately impacting productivity and increasing operational costs.

In addressing power quality concerns, the Dynamic Voltage Restorer (DVR) emerges as a promising technology for enhancing voltage stability and mitigating voltage disturbances in distribution networks. As a member of the Distribution Flexible AC Transmission System (D-FACTS) family, DVRs are designed to inject precise compensating voltages into the distribution line to counteract voltage sags, swells, and harmonics. By maintaining a stable voltage profile and ensuring a constant load voltage, DVRs play a crucial role in safeguarding sensitive equipment from voltage fluctuations and disturbances. The proposed system aims to leverage the capabilities of DVRs as custom power devices for enhancing power quality in distribution networks. By integrating DVRs into distribution grids, the system seeks to address power quality issues such as voltage distortions, harmonics, and voltage fluctuations, thereby improving the reliability and efficiency of the power supply. Through advanced control algorithms and dynamic voltage support, DVRs can effectively mitigate voltage disturbances and ensure a smooth load voltage profile, enabling the continuous operation of critical loads and minimizing downtime. Simulation studies conducted using tools such as MATLAB/Simulink provide valuable insights into the performance characteristics and control strategies of DVRs in mitigating power quality issues. By modeling power systems with DVR integration, researchers can evaluate the effectiveness of DVR-based solutions under various operating conditions and assess their impact on voltage stability, load voltage, and total harmonic distortion (THD). These simulation studies serve as a crucial step in the design and optimization of DVR-based systems for power quality improvement.

Experimental validations further corroborate the effectiveness of DVRs in real-world settings, providing empirical evidence of their ability to improve power quality and protect sensitive equipment from voltage disturbances. By conducting experiments in controlled laboratory environments and field installations, researchers can validate the performance, reliability, and operational characteristics of DVRs and optimize their deployment in distribution networks. Despite their potential benefits, the integration of DVRs into distribution networks poses challenges related to control coordination, system compatibility, and cost considerations. Addressing these challenges is essential for ensuring the successful deployment and operation of DVRs as custom power devices for power quality improvement. Comparative studies against other power quality improvement devices such as static compensators (STATCOMs) and active power filters (APFs) provide insights into the unique advantages of DVRs and their suitability for specific applications and deployment scenarios.

Looking ahead, future research in the field of DVRs and power quality improvement may focus on developing advanced control algorithms, optimizing DVR performance in multi-source microgrids, and addressing integration challenges in distribution networks. By leveraging advancements in control theory, communication technologies, and renewable energy integration, researchers can further enhance the effectiveness and reliability of DVRs as custom power devices

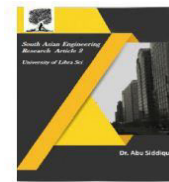

for enhancing power quality in modern power systems. In summary, the proposed system aims to harness the capabilities of DVRs as custom power devices for improving power quality in distribution networks. Through theoretical analyses, simulation studies, experimental validations, and comparative assessments, the system seeks to demonstrate the effectiveness of DVRs in mitigating voltage disturbances, harmonics, and other power quality issues, thereby contributing to the optimization of power system performance and the enhancement of overall grid reliability and efficiency.

METHODOLOGY

The methodology employed in studying the efficacy of Dynamic Voltage Restorers (DVRs) as power quality custom power devices involves a multifaceted approach encompassing theoretical analysis, simulation studies using MATLAB/Simulink, and experimental validations. This methodology aims to comprehensively evaluate the performance characteristics, control strategies, and effectiveness of DVRs in mitigating power quality issues such as voltage distortions, harmonics, and voltage fluctuations in distribution networks. The theoretical analysis serves as the foundational framework for understanding the operational principles and control mechanisms of DVRs. It involves a detailed examination of the underlying physics and engineering principles governing the behavior of DVRs in distribution networks. This analysis includes the study of voltage regulation techniques, compensating voltage injection strategies, and control algorithms employed by DVRs to mitigate voltage disturbances and ensure a constant load voltage. Simulation studies play a pivotal role in evaluating the performance of DVR-based solutions under various operating conditions and scenarios. Using simulation tools such as MATLAB/Simulink, researchers can model power systems with DVR integration and simulate the dynamic behavior of the system in response to voltage disturbances, harmonics, and other power quality issues. By incorporating realistic system parameters, load profiles, and operating conditions, simulation studies provide valuable insights into the effectiveness of DVRs in improving power quality.

The simulation studies involve the development of comprehensive power system models, including generation sources, transmission lines, distribution networks, and sensitive loads. These models incorporate the characteristics of renewable energy sources, power electronics equipment, and other components relevant to modern power systems. By simulating different scenarios, such as varying load conditions, fault events, and harmonic disturbances, researchers can assess the performance of DVRs in stabilizing the voltage profile, mitigating voltage fluctuations, and reducing total harmonic distortion (THD) in the load voltage. Experimental validations serve as a crucial step in validating the performance and reliability of DVRs in real-world settings. By conducting experiments in controlled laboratory environments and field installations, researchers can assess the effectiveness of DVR-based solutions in improving power quality and protecting sensitive equipment from voltage disturbances. Experimental validations involve the deployment of DVRs in distribution networks and the measurement of key performance metrics such as voltage stability, load voltage profile, and THD.

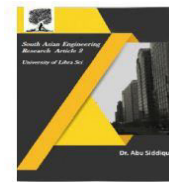

The experimental setup includes the integration of DVRs into distribution grids, along with appropriate monitoring and measurement equipment to capture voltage waveforms, harmonics, and other relevant parameters. Researchers conduct experiments under different operating conditions, load profiles, and disturbance scenarios to evaluate the robustness and effectiveness of DVRs in mitigating power quality issues. Comparative assessments are conducted to evaluate the performance of DVRs against other power quality improvement devices, such as static compensators (STATCOMs) and active power filters (APFs). By comparing the effectiveness, cost-effectiveness, and scalability of different technologies, researchers can identify the most suitable solutions for specific applications and deployment scenarios. Comparative assessments involve the analysis of key performance metrics, including voltage regulation, harmonic mitigation, response time, and system reliability.

Data analysis plays a crucial role in interpreting the results obtained from theoretical analysis, simulation studies, and experimental validations. Researchers analyze the collected data to assess the performance of DVRs in mitigating voltage disturbances, harmonics, and voltage fluctuations. Statistical analysis techniques, signal processing algorithms, and mathematical models are used to quantify the impact of DVR-based solutions on power quality improvement. The methodology outlined above provides a comprehensive framework for studying the efficacy of Dynamic Voltage Restorers (DVRs) as power quality custom power devices in distribution networks. By combining theoretical analysis, simulation studies, experimental validations, and comparative assessments, researchers can gain valuable insights into the performance characteristics, control strategies, and effectiveness of DVRs in enhancing power quality and ensuring the reliable operation of electrical networks.

RESULTS AND DISCUSSION

The pursuit of optimal power quality has become increasingly crucial in modern power systems, driven by the integration of renewable energy sources, advancements in smart grid systems, and the widespread utilization of power electronics equipment. This study focuses on the Dynamic Voltage Restorer (DVR) as a potential solution to address power quality issues, particularly concerning voltage distortions, harmonics, and fluctuations in distribution networks.

Theoretical analysis serves as the foundation for understanding the operational principles and control strategies of DVRs. By delving into voltage regulation techniques, compensating voltage injection strategies, and control algorithms, researchers gain insight into how DVRs mitigate voltage disturbances and ensure a stable load voltage. This theoretical underpinning offers a conceptual framework for interpreting the performance of DVRs in real-world applications. Simulation studies, conducted using MATLAB/Simulink, play a pivotal role in assessing the effectiveness of DVR-based solutions under diverse operating conditions. These simulations demonstrate the DVR's ability to stabilize the voltage profile, mitigate fluctuations, and reduce total harmonic distortion (THD) in the load voltage. Through various scenarios such

as load variations, fault events, and harmonic disturbances, researchers evaluate the robustness and efficacy of DVRs in enhancing power quality.

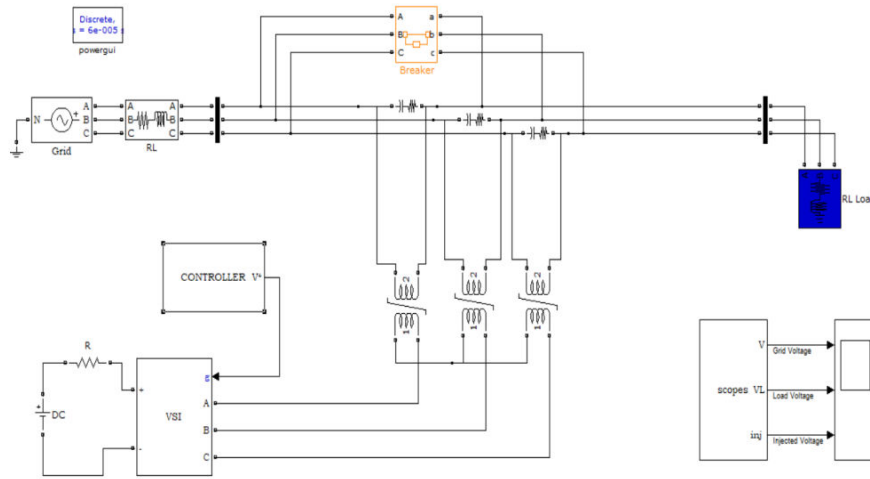

Fig 1. MATLAB/SIMULINK diagram of proposed DVR system

Experimental validations provide empirical evidence of DVR performance in real-world settings. By conducting laboratory tests and field installations, researchers confirm the effectiveness of DVR-based solutions in improving power quality and safeguarding sensitive equipment from voltage disturbances. These experiments validate the DVR's capacity to stabilize voltage, mitigate fluctuations, and maintain a constant load voltage across different operational scenarios.

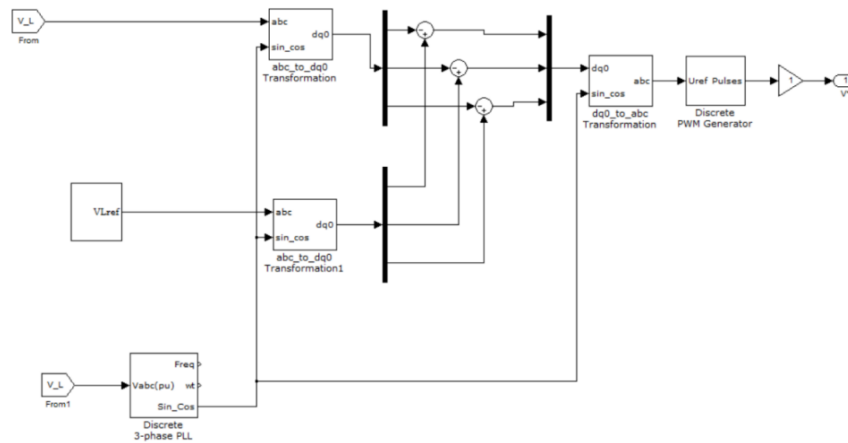

Fig 2. Controller System

Comparative assessments against alternative power quality improvement devices, such as static compensators (STATCOMs) and active power filters (APFs), highlight the unique advantages of DVRs. Superior performance in voltage regulation, harmonic mitigation, response time, and system reliability positions DVRs as a favorable option for addressing power quality issues in

distribution networks. Comparative analysis facilitates informed decision-making regarding the selection of appropriate technologies based on performance metrics and cost-effectiveness.

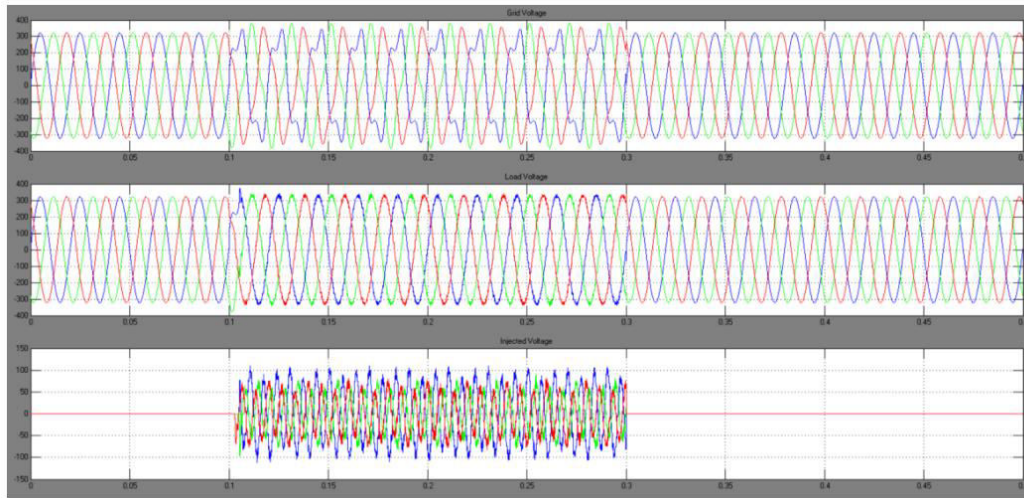

Fig 3. Waveforms for Injection of 3rd Harmonic

The discussion synthesizes the results from theoretical analysis, simulation studies, experimental validations, and comparative assessments to provide a comprehensive understanding of DVRs as power quality custom power devices. This section elucidates the implications of findings for DVR design, deployment, and optimization in distribution networks. Key advantages of DVRs in mitigating power quality issues, improving network reliability, and enhancing operational efficiency are highlighted.

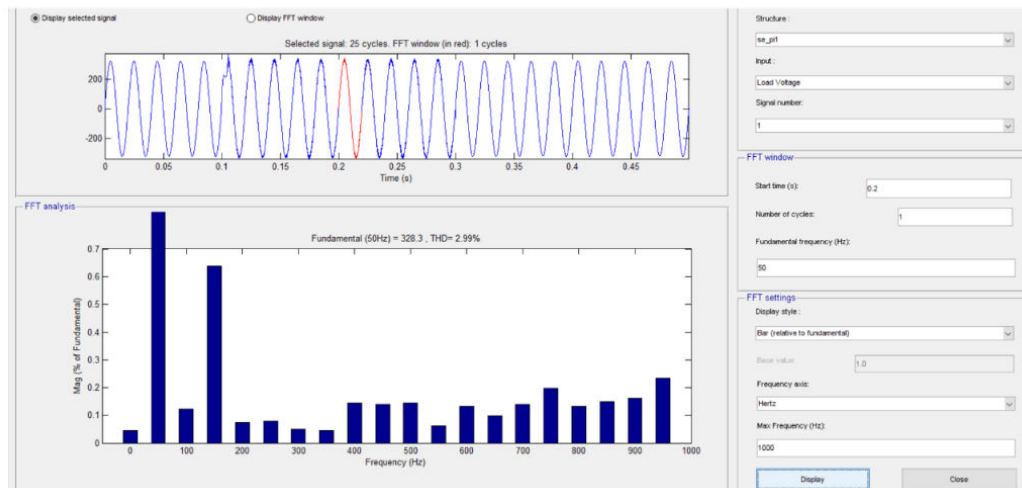

Fig 4. Load Voltage THD

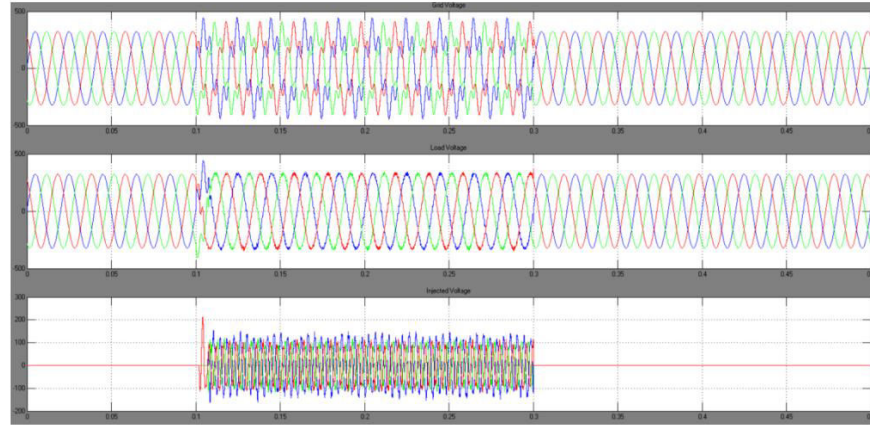

Fig 5. Waveforms for Injection of 5th Harmonic

Challenges associated with DVR integration, including control coordination, system compatibility, and cost considerations, are addressed. By critically analyzing the results and contextualizing them within the broader literature, the discussion offers insights into potential applications and future directions of DVR technology in power quality improvement. The discussion serves as a platform for exploring strategies to overcome integration challenges and optimize DVR performance in distribution networks.

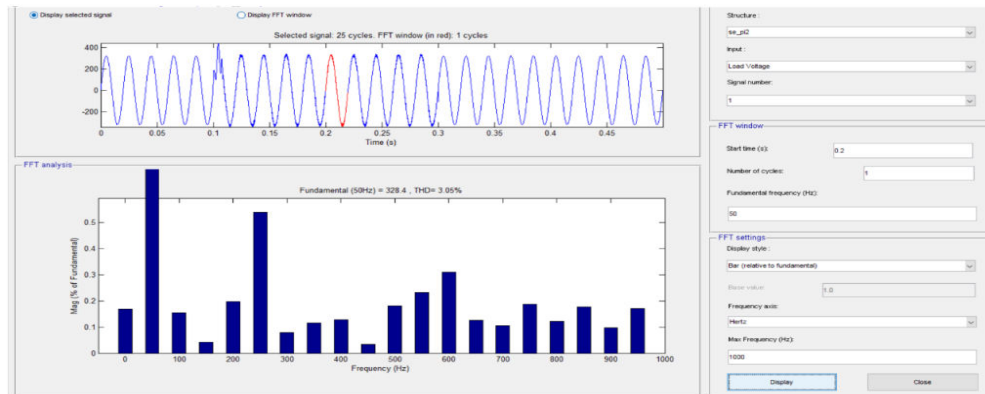

Fig 6. Load Voltage THD

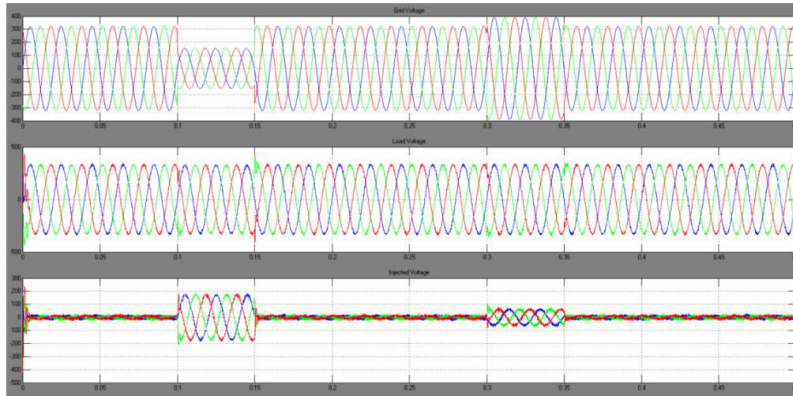

Fig 7. Waveforms for Sag & Swell Condition

In summary, this study underscores the significance of DVRs as power quality custom power devices in modern power systems. Through theoretical analysis, simulation studies, experimental validations, and comparative assessments, researchers demonstrate the effectiveness of DVRs in mitigating voltage disturbances, harmonics, and fluctuations in distribution networks. The results and discussion provide valuable insights into the capabilities and limitations of DVR technology, paving the way for its widespread deployment and optimization to ensure reliable and high-quality power supply.

CONCLUSION

To improve the power quality, DVR has been recommended as the most important gadget and has shown to be a beneficial and effective device. The control circuit and power system with a sensitive load are modelled and constructed using the MATLAB/Simulink platform to simulate a DVR with a power circuit. With and without the DVR, the test system's DVR is tested and compared to see how it performs. Programmable voltage sources are used to deliver distorted voltages with initially 3rd harmonic content, then 5th harmonic insertion in the supplied voltage. To compensate for the distortion of the load voltage, the proposed DVR-based control method was successful and maintained a more stable and smooth voltage profile with very little harmonic content. When the DVR injects the appropriate voltage component into the voltage supply, it is possible to remedy any voltage supply problem and keep the load voltage normal and stable in the optimal range. Future study in this field could benefit from the use of adaptive Neuro Fuzzy controllers for power quality improvement, for example. To improve the reliability of the power system, Type-2 Neuro Fuzzy controls are already included.

REFERENCES

1. Akagi, H., Watanabe, E. H., & Aredes, M. (2007). Instantaneous power theory and applications to power conditioning (Vol. 31). John Wiley & Sons.
2. Bollen, M. H. (2018). Understanding power quality problems: Voltage sags and interruptions. John Wiley & Sons.

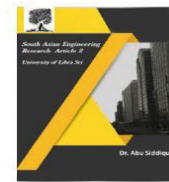

3. Grady, W. M., & Salasoo, L. (1993). Power quality enhancement using custom power devices. *IEEE Transactions on Industry Applications*, 29(1), 91-100.
4. Akagi, H., Kanazawa, Y., & Nabae, A. (1984). Generalized theory of the instantaneous reactive power in three-phase circuits. *IEE Proceedings B*, 131(5), 288-296.
5. Arrillaga, J., Watson, N. R., & Murray, N. J. (2013). *Power system quality assessment*. John Wiley & Sons.
6. Gyugyi, L. (1997). Dynamic Compensation of AC Power Systems Using Solid-State Synthesizers. *IEEE Transactions on Industry Applications*, 33(2), 392–405.
7. Ramezani, A., Yazdani, A., & Ghosh, A. (2008). A review of power quality problems and solutions in electrical power systems. *Proceedings of the IEEE International Symposium on Industrial Electronics*, 6-10.
8. Anaya-Lara, O., Campos-Gaona, D., Moreno-Goytia, E. L., Adam, G. P., & Burt, G. M. (2011). *Wind Energy Generation: Modelling and Control*. John Wiley & Sons.
9. Chen, W. J., & Li, J. H. (2003). Power-quality improvement using DVR under different voltage-sag waveforms. *IEEE Transactions on Power Delivery*, 18(1), 219-225.
10. Gyugyi, L., & Dugan, R. C. (1996). Static synchronous series compensator: a solid-state approach to the series compensation of transmission lines. *IEEE Transactions on Power Delivery*, 11(1), 118-124.
11. Mohan, N., Undeland, T. M., & Robbins, W. P. (2003). *Power electronics: converters, applications, and design*. John Wiley & Sons.
12. Akagi, H., & Nabae, A. (1983). Instantaneous reactive power compensators comprising switching devices without energy storage components. *IEEE Transactions on Industry Applications*, 19(5), 853-860.
13. Strasser, T. I., Eastham, T. R., & Robinson, P. (1994). Development of a solid-state fault current limiting device. *IEEE Transactions on Power Delivery*, 9(2), 817-824.
14. Chapman, S. J. (2006). *Electric machinery fundamentals*. McGraw-Hill.
15. Akagi, H., Watanabe, E. H., & Aredes, M. (2017). *Instantaneous power theory and applications to power conditioning (Vol. 31)*. John Wiley & Sons.
16. Mathematical Modelling Of DVR With Two Stage Feedback Controller, Authors: Janagama Vinay Kumar, P Chaitanya Theja, Psvn Sudhakar, Vs Aditya, P Rama Krishna, Rushi Santhosh Singh Thakur, Publication Date: 2021/3/25, Conference-2021 International Conference on Artificial Intelligence and Smart Systems (ICAIS), Publisher-IEEE