

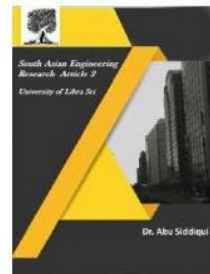

2581-4575



A PATIENT FALL DETECTION SYSTEM BY USING SENSORS BASED IOT

M.VENKATESH¹, D. SATYANARAYANA²

1 M.Tech [ES] PG Scholar, Department of ECE, St.Mary's Group of Institutions, Guntur, Ap, India.
venkatesh.marella114@gmail.com

2 Associate Professor, Department of ECE, St.Mary's Group of Institutions, Guntur, Ap, India.
satyaniet@gmail.com

Abstract: Falls in older adults are a major cause of morbidity and mortality and are a key class of preventable injuries. This paper presents a patient-specific (PS) fall prediction and detection prototype system that utilizes a single tri-axial accelerometer attached to the patient's thigh to distinguish between activities of daily living (ADL) and fall events. The proposed system consists of two modes of operation: 1) fast mode for fall prediction (FMFP) predicting a fall event (300msec-700msec) before occurring, 2) slow mode for fall detection (SMFD) with a 1-sec latency for detecting a fall event. The wireless transmission and updating of the data on the world wide web using a ARM7 and the concept of "Internet of Things" aids this. The online, real-time graphs give an insight on the heartbeat rate trend of the patient, which becomes extremely useful for reference purposes; the major advantage being, the data can be accessed from all over the world on any basic computing system. Further, the proposed method becomes highly cost effective when applied for a number of individuals at a time and can, in turn, reach the relatively lower strata of the society.

Keywords: ARM7 Controller, Temperature Sensor, Pulse Sensor, MEMS.

1.Introduction:

Presently a days populace maturing is extraordinary ever of and begun in the western world amid the twentieth century. It is considered as a human example of overcoming adversity, through the achievement of open therapeutic and wellbeing headways. In any case, this maturing procedure likewise puts a considerable measure of difficulties with respect to national advancement, issues concerning health of the elderly individual, the supportability of families, and the capacity of human services framework to accommodate maturing populaces. As of

late, there are numerous kinds of consumer electronic gadgets, for example, sensors and actuators have been created for home system applications. A buyer home system usually contains different kinds of electronic devices like sensors, remote apparatuses, and actuators, with the goal that home clients can control in a smart way or savvy and programmed approach to enhance their personal satisfaction.

As of late, especially with the ages in Micro-Electro-Mechanical Systems (MEMS) innovation which has encouraged the development of brilliant sensors. These sensors are modest, with



2581-4575

International Journal For Recent Developments in Science & Technology



A Peer Reviewed Research Journal

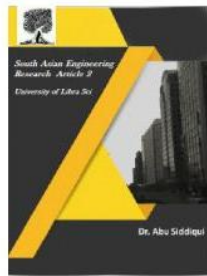

constrained preparing and processing backing, and they are inexpensive compared to customary sensors. These sensor hubs can detect, measure, and gather data from the conditions and, based on some nearby choice process, they can transmit the detected information to the client. In a couple of years prior some agent advances to perform a home Network incorporate IEEE 802.11, Bluetooth, GSM, wifi module and so forth. Wi-Fi is reasonable for consumer home systems on the grounds that different sensors can be extended to gather home information data in a circulated, self-organizing manner with moderately low power. In this paper utilized a GSM module which is reasonable for long separation correspondence it transmits the message to a cell phone of guardian or relatives of the fallen subjects.

Amid the most recent decades, numerous arrangements have been proposed for elderly fall identification. Such arrangement can be classified into three types. One of the most punctual arrangements 3-pivot Micro-Electro-Mechanical Systems accelerometer, such framework persistently screens the elderly individuals toward all path and when it identifies a fall, guardians are advised of the event of such occasion. In a decade ago many studies called attention to proposed out that the elderly frequently postpone medicines after falls happen in light of the confusion. They can't use phones to illuminate the therapeutic treatment about the correct fall area or crisis help, the vast majority of the fall just lying on the ground and missing the best safeguard timing, which may even prompt serious

outcomes. Numerous old individuals with fall encounters are not willing to lead the recovery work later on the grounds that they are stressed to fall once more. They regularly restrain the scope of activities by themselves, which influences their life quality truly as well as results in their muscle decay; some of them even require long term care in their every day life

2. Existing System

Modern technologies are equipped with different sensing devices such as accelerometers, gyroscopes, and magnetometers. The accelerometer (also called inertial sensor or G-sensor) can measure the proper acceleration felt by the sensors, and can have many applications on gesture based interactions with smart phone such as automatic screen rotation. This study focus on the advanced technologies to help elderly person and detect the fall by various ways. With the purpose to successfully detect falls, there are different types of fall detection methods for elderly people, namely wearable device based methods, vision based methods, and ambient based methods. The literature reviewed provides evidence of the lack of a common approach. Noury et al. [3] classify the different studies on fall detection according to whether they only focus on the detection of the impact shock, or they also include the detection of the post fall phase. Zhang, Ren and Shi [1] proposed HONEY (Home healthcare sentinel system), a three-step detection scheme which consisted of an accelerometer, audio, image and video clips. Its innovation was to detect falls by leveraging a tri axial accelerometer, speech



2581-4575

recognition, and on-demand video. Bagalàet al. [2] gave an evaluation of accelerometer-based fall detection algorithms on real-world falls. They found that the sensitivity and specificity on real falls are much lower than that in an experiment environment. This inspires researchers to take more real world scenarios into consideration. Abbateet al. [4], [5] proposed a smart phone based fall detection system with consideration of the acceleration signal produced by fall-like activities of daily lives. Yu et al. [6] proposed a vision based fall detection method by applying background subtraction to extract the foreground human body and post processing to improve the result. Sazonov et al [7] developed an in-shoe pressure and acceleration sensor system that was used to classify activities I clouding sitting, standing, and walking with the ability of detecting whether subjects were simultaneously performing arm reaching movements. Recent advances in smart phone technology have led to their use in fall detection systems. Often, these systems combine fall detection with localization of the person who fell via wifi-based method [8,9]. Yavuz et al [10] developed a fall detection system that relied upon the accelerometers available in smart phones and incorporated different algorithms for robust detection of falls. WEALTHY [11], led to the development of garment-based wearable sensors aiming at general health monitoring of people in the home and community settings.

3. Block diagram:

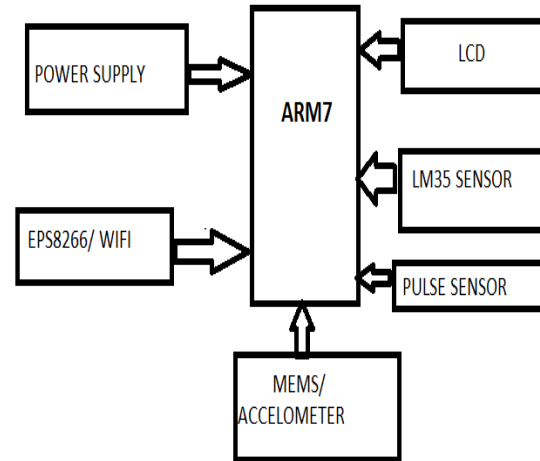

Fig: block diagram

4) System Overview

i) **Power Supply:** This section is meant for supplying Power to all the sections mentioned above. It basically consists of a Transformer to step down the 230V ac to 9V ac followed by diodes. Here diodes are used to rectify the ac to dc. After rectification the obtained rippled dc is filtered using a capacitor Filter. A positive voltage regulator is used to regulate the obtained dc voltage.

ii) **ARM7:** ARM is the abbreviation of Advanced RISC Machines, it is the name of a class of processors, and is the name of a kind technology too. The RISC instruction set, and related decode mechanism are much simpler than those of Complex Instruction Set Computer (CISC) designs.

iii) **LCD Display:** This section is basically meant to show up the status of the project. This project makes use of Liquid Crystal Display to display / prompt for necessary information.

iv) **Temperature sensor:** Thermistors are a temperature sensing devise. It is used to



2581-4575

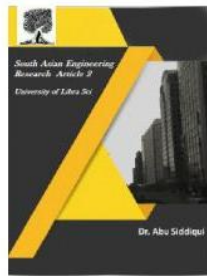

sense the temperature. In this project by depends on the value of temperature the exhaust fan will run.

v) **Pulse sensor:** Heart rate data can be really useful whether you're designing an exercise routine, studying your activity or anxiety levels or just want your shirt to blink with your heart beat. The Pulse Sensor Amped is a plug and-play heart-rate sensor. Simply clip the Pulse Sensor.

vi) **Accelerometer:** An inertial mass suspended by springs is acted upon by acceleration forces that cause the mass to be deflected from its initial position. This deflection is converted to an electrical signal, which appears at the sensor output. The application of MEMS technology to accelerometers is a relatively new development.

5. RESULTS

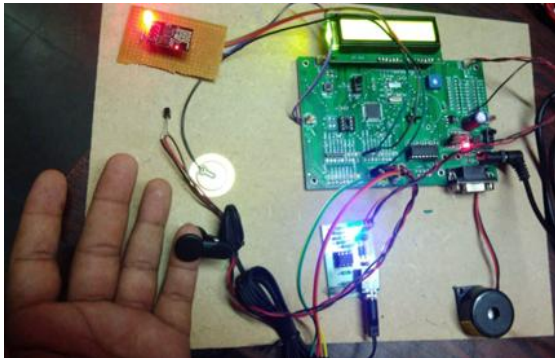

Fig: Hardware Implementation



Fig: Output Values

6 CONCLUSIONS AND FUTURE WORK

In this paper, an enhanced fall detection system based on Wearable device was proposed and implemented that successfully detected accidental falls in a consumer home application. By using information from an accelerometer, smart sensor and cardio tachometer, the impacts of falls can successfully be distinguished.

Wearable device is completely safe because it is worn on the outside of the body not inside the body. This work is of low cost, very effective, and productive. But there is always room for improvement. This merchandise has been designed as a prototype and requires further developments for using it in assorted applications. This system can be further expended in developing a Windows application which can support windows phone and the wearer device must be small and unobtrusive in the form of compact watch and it should not label people.

REFERENCES:

[1] Media Aminian and Hamid Reza Naji "A Hospital Healthcare Monitoring System Using Wireless Sensor Networks," Department of Computer, Science and Research branch, Islamic Azad University, Kerman, Iran and College of Electrical and Computer Engineering, Kerman Graduate University of Technology, Iran, vol 4,2013.

[2] G. Virone, A. Wood, L. Selavo, Q. Cao, L. Fang, T. Doan. He, R. Stoleru, S. Lin, and J.A. Stankovic Department of Computer Science, University of Virginia An Advanced Wireless Sensor Network for Health Monitoring (2011).



2581-4575

International Journal For Recent Developments in Science & Technology



A Peer Reviewed Research Journal

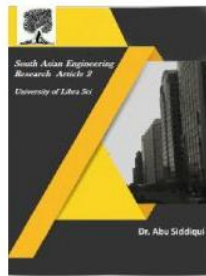

[3] Singh, Sr. Asst. Prof. Ravi Mishra 1(ME II Year VLSI Design, Department of EC, SSCET, Gunwani, Bhilai Nagar (C.G), India) 2(Sr. Asst. Prof. Department Of EEE, SSCET, Gunwani, Bhilai Nagar (C.G), India) Microcontroller Based Wireless Temperature and Heart Beat Read-Out Nisha (2008).

[4] Cirkovic, Predrag, Aleksic, Anda Processing of Medical Signals (ECG) in Wireless Sensor Networks (2007).

[5] C. E. Perkins, E. M. Royer, "Ad-hoc on-demand distance vector routing," Second IEEE Workshop on Mobile Computing System and Applications, 1999, proceedings. WMCSA'99, pp.90-100, Feb. 1999.

[6] WHO: "Connecting for health global vision, local insight report for the world summit on the information society" (WHO 2005).